



Percussion Ensembles at SPARK: New Light

September 25, 2022 | 1:00-2:30pm

FREE | In-person at the Peale

RSVP in advance

On the last day of the *SPARK: New Light* exhibition, join us for a lively musical program featuring the Towson University Percussion Ensemble, the UMBC Percussion Ensemble, and Umbilicus, a percussion ensemble with UMBC and Towson-affiliated players.

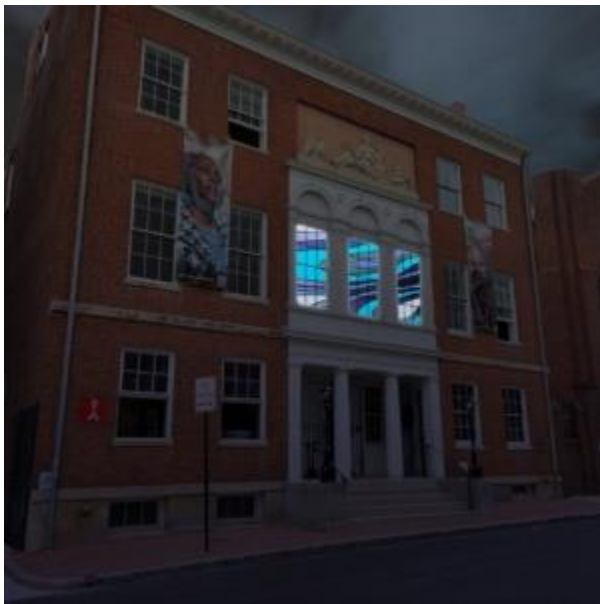

Windows 26 Illumination

September 23-24, 2022

FREE | In-person at the Peale

No tickets necessary! View the projection after dark outside the Peale!

Join us for a participatory workshop to help us guide the Peale's programming and decision-making process. The aim is to ensure that the programs and exhibitions hosted by the Peale online and in its historic building continue to be driven grassroots-up, by Baltimore's communities and creators.



***SPARK: New Light* exhibition**

August 13, 2022 - September 25, 2022

FREE | In-person at the Peale

Thursdays-Fridays: 3-7pm

Saturdays-Sundays: 10-4pm

SPARK: New Light will ignite your imagination. Enjoy the illuminating creations of 24 Towson University and UMBC artists and their collaborators in the fifth edition of *SPARK*, generously sponsored by PNC Bank.



Wanted: Your Memories of Winter

September 11, 2022, 12-3pm (Pick your session)

September 17, 12-3pm

September 23, 5 – 7 pm

September 25, 10 – 1 pm

FREE | In-person at the Peale

Lynn Cazabon will be in the gallery ready to record your winter memories to be added into the project *Losing Winter*. *Losing Winter* is a site-specific, participatory artwork and archive of memories and emotions about winter, revealing the personal and cultural ties we have to the season and providing a window onto what we are collectively losing due to climate change impacts on weather patterns.



Lumenbox & Solargraphy Camera Workshop

September 11, 2022

1:00-2:30pm OR 2:30-4:00pm (Pick your session)

FREE | In-person at the Peale

Artist Chris Perego will share his love of the magic of photography in a hands-on Lumenbox & Solargraphy workshop on Saturday, September 11 at the Peale. In this workshop, participants will build two cameras: a Lumenbox camera and a Solargraphy camera, like the ones Chris used to create his artworks in the *SPARK: New Light* exhibition, and load them with light-sensitive material.

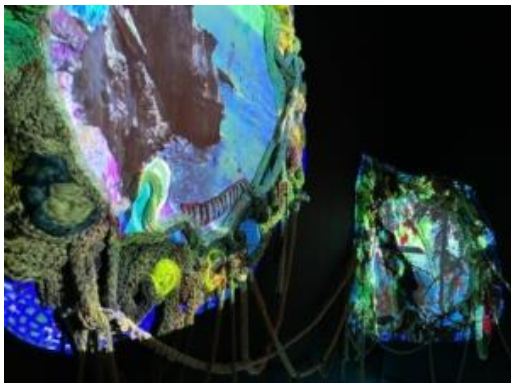

SPARK: New Light Exhibition Opening Reception

September 7, 2022, 5-8pm EDT

FREE | In-person at the Peale

SPARK: New Light will ignite your imagination. Enjoy the illuminating creations of 24 Towson University and UMBC artists and their collaborators in the fifth edition of *SPARK*, generously sponsored by PNC Bank.



(Re)writing History: Wikipedia Edit-A-Thon

August 15, 2022 | 11-2pm (EDT)

FREE | In-person at the Peale

RSVP in advance

Love or leave it, Wikipedia is THE historical resource of our time. If you've ever wondered how to edit articles and even create new histories, join us for this free Edit-a-thon. An expert wikipedian will teach us the basics! We'll start by editing articles related to the Peale.



Grand Reopening Celebrations

Open house to showcase the Peale's \$5.5 million renovations!

August 13, 2022

FREE | In-person at the Peale

After five years of extensive renovations, we're celebrating the Peale's reopening and 208th birthday! Come check out the fully renovated 1814 museum building – the oldest in the country! – illuminated by the [Spark: New Light](#) exhibition. Find your personalized brick in the "Walk of Honor" and your silhouette in the [Peale Faces](#) installation by Lauren Muney – or find out how to add yours! Hear songs of praise and Baltimore stories, take a ride in our stately new elevator, and much more, all while enjoying some of Baltimore's best food and music. We can't wait to see you again at the Peale!



[Weekly Chinese Museum Field Trips: Meet the Terracotta Army](#)

July 10-July 23, 2022

Pay What You Can, Starting at \$5

Online

RSVP in advance

Hosted by the Peale online, Baltimore's [Asian Pasifika Arts Collect](#) presents three weeks of drop-in virtual field trips. Enjoy virtual field trips to learn about Chinese history, art, and culture, taught in English by Chinese museum experts and specialists.



Visibility is Your Superpower! Art Workshop

Family workshops in conjunction with *THE AMAZING BLACK MAN: Kumasi J. Barnett* exhibition

June 25, July 9, and July 16: 10am-12pm, refreshments included

FREE | In-person at the Peale

An educational and art-making workshop for kids (adults are welcome too!). Imagine a world where being visible is your superpower. And what does it mean to be visible in a world where invisibility is expected? Artist and educator, Chrys Seawood, leads this family workshop to develop literacy as well as creative skills. Make art with comic books while being inspired by the art of Kumasi J. Barnett displayed in the gallery around you!



Accomplished Arts Apprentices' Success Appreciation Program

July 15, 2022, 4-6PM

FREE | In-person at the Peale

Come celebrate the first cohort of the Accomplished Arts Apprentices as they complete their program at the Peale. In this “shark tank” style event, the apprentices will pitch the business plans they have developed as part of the program to solicit investment and customers! See a mini-exhibit of their experiences and work during their apprenticeships, and hear from program director Jeffrey Kent on lessons learned and where the AAA program is going next.



Addressing the White Racial Imagination in Comic Books: Artist Talk w/ Kumasi J. Barnett, Darryl Peterkin, and Jeffrey Kent

July 14, 2022, 6-8pm

FREE | In-person at the Peale

RSVP in advance

In this panel discussion, artist Kumasi J. Barnett and exhibition curator, Jeffrey Kent, are joined by Dr. Darryl Peterkin, author and American historian from Morgan State University. “When I was introduced to Baltimore-based artist Kumasi Barnett’s artwork in New York at the Armory Show in 2019, I was blown away by the content editing and visual editing process. So much that I felt very fortunate to have an opportunity to exhibit his artwork at the Peale.”

—Jeffrey Kent, Chief Curator, the Peale



THE AMAZING BLACK MAN: Kumasi J. Barnett solo exhibition

May 21, 2022 - July 16, 2022

FREE | In-person at the Peale

Thursdays-Sundays (hours vary)

"Kumasi J. Barnett's works serve as important tools for progress in their ability to confront and acknowledge prejudice and hypocrisy. By utilizing the format of the comic book, which at its core revolves around a concept of good and evil, his interventions remind the viewer to always question, consider and adapt our understanding of right and wrong. While Kumasi's works evolve as he reflects on the world around him, they will serve as markers in time—20, 60, 100 years on—reflecting a human condition that is capable of change, and hopefully problems that we are able to collectively solve and move past." - Virginia Martinsen (Lowell Ryan Projects, Los Angeles California)



Breathing Black Film Screening

July 9, July 10: Various Times

\$35-\$75 | In-person at the Peale

Breathing Black is a documentary film that follows nine Black Baltimoreans as they find joy amidst the global COVID-19 Pandemic and a summer of reckoning with the continued genocide of the Black body. This special screening, hosted by Submersive Productions at the Peale, will raise funds to help keep the film going as we continue to market and submit it to festivals. The film's director and other participants will be present, and each showing will include a brief talk-back.



Black Comics: Politics of Race + Representation

July 7, 2022 | 5:00pm (EDT)

Online Program

Join Dr. Sheena Howard for a free, online lecture as she explores the politics of race and representation in Black comics. This program has been created in conjunction with the exhibition *The Amazing Black Man*, a series of provocative comic book covers by the acclaimed artist Kumasi J. Barnett, on display at the Peale from May 21 to July 16, 2022.

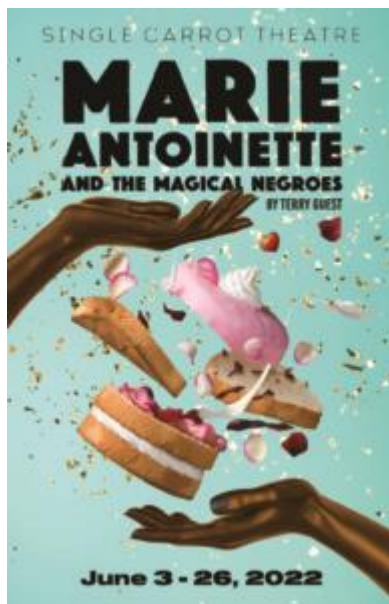

Single Carrot Theater Performances: *Marie Antoinette and the Magical Negroes*

June 3, 2022 - June 26, 2022

In-person at the Peale

Liberté, égalité, fraternité, ou la mort! (Liberty, equality, fraternity, or death!), echoes the rallying cry of activists fighting through militant resistance, peaceful protest, and collaborative

action to overthrow oppressive governments and corrupt, inequitable systems. Set against the opulent background of 16th-century Versailles and the French revolution, *Marie Antoinette and the Magical Negroes* delves deep into the history of race and revolution in America. This high-fashion, club-swirling, time-jumping theatre extravaganza asks what is needed to keep the revolution alive for centuries to come.



MICA: *NOVUS* exhibition

May 27, 2022 - June 26, 2022

FREE | In-person at the Peale

Thursdays-Sundays (hours vary)

Exhibition opening reception: May 26, 6-8pm

NOVUS foregrounds a strain of artistic production operating outside of conventional forms, frameworks, and paradigms. In this exhibition at the historic Peale — the nation's first purpose-built museum — emerging multidisciplinary artists actively define the future of art. Through site-specific installations, wearable art, and digital or virtual works, these artists urge the use of new strategies for creative interventions in daily life.



***Voices of a Black Butterfly* Film Premiere**

Featured Guest: Dr. Lawrence T. Brown, Author, *The Black Butterfly: The Harmful Politics of Race and Space in America*

May 13, 2022 | 5:30-7:00pm (EDT)

Admission: \$15 – To Support BNHA Heritage Area Youth Initiatives

What is it to survive and thrive in a city that doesn't always acknowledge your presence and history? *Voices of a Black Butterfly*, the latest documentary produced by The Baltimore National Heritage Area, explores the cultural aspects of living in Baltimore, where history is both enriched and complicated by its length and its diversity.



Lunch and Learn: From Treasure House to Production House: Stories of the Peale from 1814 to the Future

May 12, 1:00pm (EDT)

Enoch Pratt Free Library

Free online

Dr. Nancy Proctor, founding Executive Director of the Peale Center for Baltimore History and Architecture and now its Chief Strategy Officer, will share key stories of the Peale Museum from its opening in 1814, through the recent renovations, to its new role as Baltimore's Community Museum. This talk will include an invitation to attendees to collaborate with the Peale on

redefining the role of museums in society and building the largest digital archive of Baltimore stories in the world. Presented in partnership with The Maryland State Archives and The Maryland Four Centuries Project.



History as a Mangy Dog: Abolitionists, Indian Removal, and the Price of Denial

It's More Than History Lecture Series, sponsored by the Baltimore National Heritage Area

Friday, April 29 | 12:00pm -1:00pm (EDT)

Free online | RSVP in advance

Be there with us for a compelling talk by Paul Chaat Smith (Comanche), curator of *The Americans* exhibition at the National Museum of the American Indian and author of *Everything You Know about Indians Is Wrong*. This lunchtime talk is FREE and presented by the Baltimore National Heritage Area's "It's More than History" lecture series.



[The Guardians Project: Inspiration from Baltimore's Black women leaders](#)

**It's More Than History Lecture Series, sponsored by the Baltimore National Heritage Area
Friday, March 25, 2022 | 12:00pm -1:00pm (ET)**

Hear about the inspiring work of [The Guardians project](#) with artistic director, Whitney Frazier and Black women leaders who are fighting for better, healthier communities in Baltimore, including Tayler Mugar (Harlem Park), Samirah (Sandtown/West), Audrey Carter (Oliver), and Sharon Snow (Cylburn). This lunchtime talk is FREE and presented by the Baltimore National Heritage Area's "It's More than History" lecture series.



[Covid Chronicles: Baltimore Youth Share Stories about Their Lives During the Pandemic](#)

Friday, March 25, 2022

Free, In-person | 5:00 pm (ET)

The Stoop Storytelling Series, in collaboration with The Peale, presents "Covid Chronicles." Come hear true, personal stories about how Covid has impacted the lives of Baltimore's youth. Hosted by Stoop Storytelling Series' Jessica Henkin and [WYPR's](#) Aaron Henkin.



***Unmarked* Film Screening with co-director and archival expert Chris Hayley**

**It's More Than History Lecture Series, sponsored by the Baltimore National Heritage Area
Friday, February 25, 2022 | 12:00pm -1:00pm (ET)**

Join us for a complete screening of *Unmarked*, a new documentary on the preservation of African American burial sites with co-producer Chris Hayley. This lunchtime talk is FREE and presented by the Baltimore National Heritage Area's "It's More than History" lecture series.

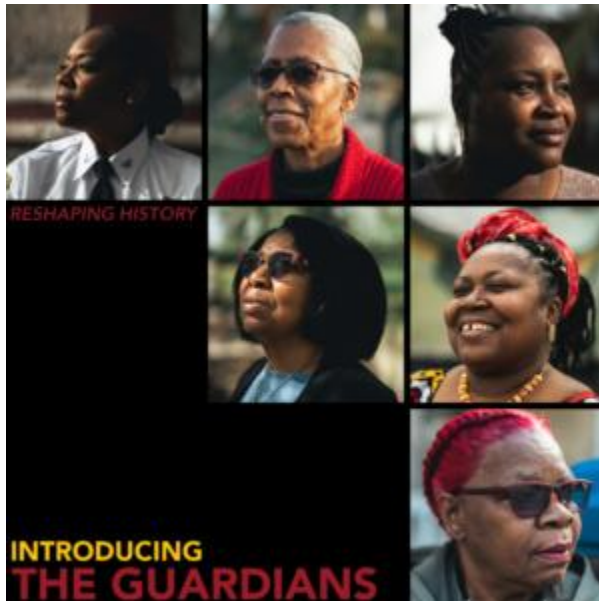

***The Guardians: Reshaping History* Exhibition**

October 30 2021-January 30, 2022*

In-person, Carroll Mansion

By Appointment | Email whitney@wgfstudio.com with your preferred date and time

***Proof of vaccination required**

Visit the Carroll Mansion, the Peale's home away from home during our renovation, to see an important photography exhibition, featuring the women changemakers in Baltimore. This project provides a platform for women who spend their lives fighting for a better, more equitable Baltimore.



Grit Fund Grant Information Session

January 26, 2022 | 6:00pm

Free Online

You're invited to join the Grit Fund grant team and a past recipient for an informal information session. If you plan on applying for a Grit Fund project grant, up to \$10,000, you'll want to attend!



Grit Fund Grant Information Session
December 15, 2021 | 12:00pm
Free Online

You're invited to join the Grit Fund grant team and a past recipient for an informal information session. If you plan on applying for a Grit Fund project grant, up to \$10,000, you'll want to attend!



The Guardians: Reshaping History Virtual Community Update and Second Life Launch

December 7, 2021 | 6:00pm (ET)

Online

FREE | RSVP required

Join us for a virtual event that explores the future of the Guardians and their tireless work. Hear about their community initiatives and how they plan to continue to make change in Baltimore into 2022 and beyond.

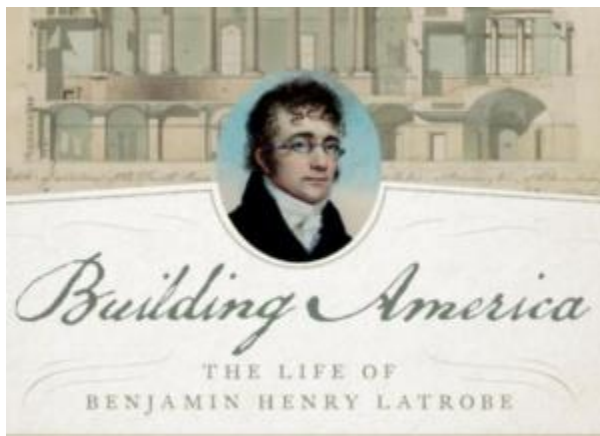

Building America: The Life of Benjamin Henry Latrobe

November 20, 2021 | 12:00pm (ET)

Online

FREE | RSVP required

Professor Jean Baker talks about Benjamin Henry Latrobe, architect and engineer, and a founding father of the United States, not of its political ideas, but of the neoclassical buildings and necessary infrastructure that expressed those ideas.



Grit Fund Grant Information Session
November 16, 2021 | 4:00pm (ET)
Free Online

You're invited to join the Grit Fund grant team and a past recipient for an informal information session on November 16, from 4:00-5:00 pm. If you plan on applying for a Grit Fund project grant, up to \$10,000, you'll want to attend!



***The Guardians: Reshaping History* Virtual Artist Talk with Whitney Frazier and Kirby Griffin**
November 16, 2021 | 6:00pm (ET)
Online

Join us for a virtual discussion and tour of *The Guardians: Reshaping History* with lead artists Whitney Frazier and Kirby Griffin. They'll talk about how the exhibition and project came to be.



***The Guardians: Reshaping History* Exhibition Opening**
November 6, 2021 | 3:00-8:00pm (EDT)
In-person, Carroll Mansion

Join us at the Carroll Mansion, the Peale's home away from home during our renovation, for the opening of an important photography exhibition, featuring the women changemakers in Baltimore. This project provides a platform for women who spend their lives fighting for a better, more equitable Baltimore. The exhibition itself will run through early 2022.



Facebook Live with Daisy Brown
With special guest: Dean Krimmel, Principal of Creative Museum Services
September 30, 2021 | 7:00 pm (EDT)

Join the Peale's storytelling ambassador, Daisy Brown, in a casual conversation with Dean Krimmel, historian and former curator of the Peale Museum back in the 1980s and beyond. They'll talk Baltimore history and more!



Virtual Tour of the Peale 2021
October 14, 2021 | 5:00pm EDT
Online

Take a virtual tour of the historic Peale Museum building, the first purpose-built museum in the country, with Chief Strategy officer, Nancy Proctor, and Chief Experience Officer, David London. Hear some of the many stories the building holds, from its founding by Rembrandt Peale, of the Peale family of artists, innovators, and entrepreneurs, to its role as the first public high school in the state of Maryland to offer a secondary education to African Americans. *Presented in partnership with Doors Open Baltimore.*



Cicada Parade-a Exhibition

September 11, 12, 18, 19

12:00pm-4:00pm

FREE | RSVP required

Carroll Mansion, 800 E. Lombard Street

The Cicada Parade-a is a large-scale collaborative art project organized by Formstone Castle Collective that has been on outdoor display around Maryland all summer. Consisting of 170 plaster cicada sculptures uniquely transformed by 170 local artists, this will be your only chance to see them all together in one place: The Peale at Carroll Mansion, in downtown Baltimore.



Facebook Live! Meet Robin Marquis and Marguerite Woods

August 26, 2021 | 7:00 pm

On Facebook! No need to RSVP

Join the Peale's storytelling ambassador, Daisy Brown, in a casual conversation with artists Robin Marquis and Marguerite Woods on Facebook. They'll talk about art, accessibility, and everything in between.



Founder's Day 2021: Virtual Celebration

Online

August 15, 2021 | 6:00pm-7:00pm EDT

This hour-long online event will include a virtual tour of the Peale's renovations, a preview of the upcoming *Guardians* exhibition, and the debut of the original score composed for the Peale's *Proximity Project* by Scott Patterson from Afro House. WYPR's Aaron Henkin reflect on the award-winning *Out of the Blocks* story series as it comes to an end, and share what is coming next from its renowned producers. See silhouette cutting in the 19th century manner by artist Lauren Muney. This event was generously supported by PNC Bank.

Online Exhibitions



[Juneteenth Stories of Freedom](#)

Saturday, June 19, 2021 | 1:00pm (EDT)

Presented in partnership with the Griots' Circle of Maryland

The Peale and the Griots' Circle of Maryland present a Juneteenth virtual storytelling event featuring African American storytellers. The celebration will unite all people in the spirit of activism inspired by the recent human rights protests. The stories of freedom will bring to life heroes from the past and others will highlight the present passion for social justice.



[Facebook Live! Meet Robin Marquis and Marguerite Woods](#)

Thursday, May 27, 2021 | 7:00pm (EDT)

Free on the Peale's Facebook Page

Join the Peale's storytelling ambassador, Daisy Brown, in a casual conversation with Robin Marquis (pictured at right) and Marguerite Woods (left). Robin Lynne Marquis (they/them) is the Accessibility Manager at the Peale, an artist, facilitator, and disability activist. Marguerite Woods is a sculptor, artist, teacher, and President of the At-Large and Board member of the NFBMD (National Federation of the Blind of Maryland).



Spring Gala

May 4, 2021 | 6:00pm (EDT)

**Tickets available by donation in any amount
Online**

Despite the many challenges of the last 12 months, there is still plenty to celebrate and a lot going on at the Peale this spring. Join us in May for a special online event to catch up on the Peale's progress with the renovation and to make a final push to close out our capital campaign, all while supporting the preservation of our National Landmark building – an anchor institution in Baltimore for more than 200 years!



Peanuts, Corned Beef, and History: Lexington Market Community Storytelling Day

April 28, 2021 | 12:00pm (EDT)

Free Online | RSVP required

Join us to hear community-sourced stories about the world-famous Lexington Market, learn about surprising new facts that have been unearthed about the market, and share your own stories about food, family, and fun. Part of the Lexington Market Public History Initiative.



It's More Than History Lecture Series, produced by the Baltimore National Heritage Area

April 23, 2021 | 12:00pm (EDT)

More than Slaves, More than Artifacts: Telling Black History at Mount Clare

Free Online

Starting with the end of slavery at Mount Clare, the evidence of enslaved people's lives was buried or disappeared from the landscape. This talk will outline some of the stories about real people who lived, worked, and raised families at Mount Clare.



***Pouring Light* Exhibition**

February 5 – March 28, 2021

Open Saturdays and Sundays, 12:00pm – 4:00pm, FREE

Carroll Mansion | 800 E. Lombard St.

How do you view Baltimore? Our perspective impacts how we speak, act and live in our city. Your viewpoint of “The Greatest City in America” greatly impacts your experience of it. In this exhibition, images are repeated. The same people and places are portrayed multiple times to contrast against each other and show the array of choices we have. Artists Julia Glatfelter and Jaz Erenberg believe that our perspective can actually change our reality.



***It's More Than History* Lecture Series, produced by the Baltimore National Heritage Area**

March 19, 2021 | 12:00pm (EDT)

Sparrow's Point Women of Steel: Virtual Discussion

Free Online | RSVP required

Hear from women who shattered the glass ceiling working at Bethlehem Steel's Sparrows Point mill, the topic of a new outdoor exhibition at the Baltimore Museum of Industry, in this one-hour Zoom discussion moderated by Michelle Stefano, from the Library of Congress.



Facebook Live with Daisy Brown
February 25, 2021 | 7:00pm (EDT)
A Conversation with Kim Rice and Jeffrey Kent
No RSVP necessary

Join the Peale's storytelling ambassador Daisy Brown as she chats with our artistic director Jeffrey Kent as well as Baltimore-based artist Kim Rice, whose recent exhibition "Kim Rice: Inheritance" garnered significant attention from the regional arts community. Facebook Live chats with Daisy Brown occur the last Thursday of the month.



It's More Than History Lecture Series, produced by the Baltimore National Heritage Area
February 19, 2021 | 12:00pm (EDT)
Double Short Film Feature and Talk

See two excellent films create by local Baltimore filmmakers:
By Any Means Necessary: Stories of Survival, directed by Tony Mendez
Not Just a Game: The Story of Savage, a film by Myles Banks, Just Stunt Productions, LLC



[Pouring Light Virtual Artist Talk](#)

February 11, 2021 | 6:00pm (EDT)

Free Online

Exhibition on view Saturdays-Sundays, 12-4pm through March 14, 2021

Artists Julia Glatfelter and Jaz Erenberg believe that our perspective can actually change our reality. Our perspective impacts how we speak, act and live in our city. Your viewpoint of “The Greatest City in America” greatly impacts your experience of it.



[Pouring Light Exhibition Opening](#)

February 5, 2021 | 5:00-9:00pm (EDT)

Carroll Mansion, 800 E. Lombard St.

Free In-Person

Exhibition on view Saturdays-Sundays, 12-4pm through March 14, 2021

Artists Julia Glatfelter and Jaz Erenberg believe that our perspective can actually change our reality. Our perspective impacts how we speak, act and live in our city. Your viewpoint of “The Greatest City in America” greatly impacts your experience of it. Take place during Baltimore Ceasefire/ Peace Challenge weekend.

Connect + Collect
ONLINE EVENT

FEB 4 THURSDAY
6:30 PM (EST)

BmoreArt

at The Peale



WITH
KIM RICE



&
**KRISTA
D. GREEN**

[Connect+Collect: BmoreArt at the Peale](#)

February 4, 2021 | 6:30pm (EDT)

Free Online

Join BmoreArt’s Jeffrey Kent and Cara Ober for a Connect+Collect Zoom with artist Kim Rice, whose exhibition, “Inheritance,” at The Peale was named one of BmoreArt’s 10 Best of 2020. Rice will be joined by Krista D. Green, the Chief Administrative Officer at The Peale and BmoreArt’s Jeffrey Kent, who curated the exhibition in his role as Artistic Director at The Peale.



Live with Daisy Brown: Facebook Chat

January 28, 2021 | 7:00pm (EDT)

Free Online

Join the Peale's storytelling ambassador Daisy Brown as she talks with Nancy Proctor, the Peale's Chief Strategy Officer, about the Peale's renovations, programs, and plans for the future. Join the conversation and add your questions and comments. This is a casual meet-up that everyone can join!



August 28, 2020-January 2021

***Inheritance* by Kim Rice**

In this timely and ground-breaking exhibition curated by the Peale's artistic director Jeffrey Kent, artist Kim Rice confronts her white privilege. ***Inheritance*** explores how Rice's "fair" complexion is exactly the cause of so much inequality for others who do not look like her. Created over the past decade, these artworks confront the harsh realities of systemic racism from the perspective of a white American woman whose ancestors enslaved hundreds of humans for hard labor.



January 21, 2021, 1:00pm (EST)

**Digital Cultures in the Pandemic: A Virtual Field Trip to the Peale in Second Life
Happens in Second Life**

Join the Peale's David London and Nancy Proctor as they chat with Prof. [Tom Boellstorff](#) at [the Peale in Second Life](#) about transition and change in the cultural sector. This chat will take place one day after the inauguration of a new President in the United States, and also during what may prove to be the period of highest COVID-19 infection. The pandemic has changed so much, and it has taken place during a time of social and political change as well. How should we think about all these transitions in the context of COVID? How do our “transitions” between the physical world and virtual worlds shape this broader sense of change? And what might not be changing in all this? Finally, how can exhibitions and cultural organizations help us understand and rethink transition in these troubled times?

This event is part of the "[Virtual Cultures in Pandemic Times](#)" project from the University of California, Irvine, and is being filmed by Bernhard Drax aka Draxtor.



January 7, 2021, 12:00pm (EST)

**Virtual Tour of *Kim Rice: Inheritance* with Kim Rice and Jeffrey Kent
Free Online**

Join artist Kim Rice and exhibition curator Jeffrey Kent as they walk through the physical exhibition at the Peale. Due to COVID-19, the exhibition is now only open for virtual tours. The show examines race, social justice, and white privilege as interpreted by Kim Rice.



December 17, 2020, 6:00pm (EST)

[New Soul Concert with Wendy Lewis](#)

Online (Free Tickets Available after December 1 with Donation to the Peale)

Hear singer Wendy Lewis and her band in an online performance that was originally supposed to take place in March! Those contributing to our Giving Tuesday efforts on December 1, 2020, get free tickets.

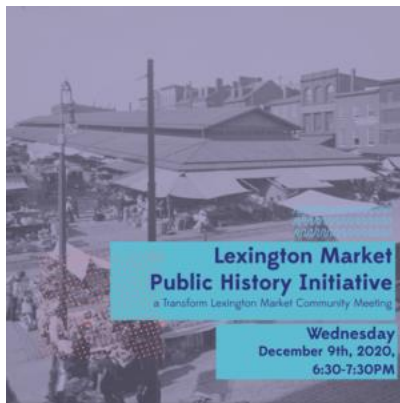

Lexington Market Public History Initiative Community Meeting

Wednesday, December 9th from 6:30-7:30PM (online)

[RVSP to attend this online meeting](#)

Join us for a Transform Lexington Market Community Meeting to learn about and discuss the Lexington Market Public History Initiative! Do you have Lexington Market stories and memories

to share? We want to hear from you! Head over to @lexington_market to RSVP; the meeting will be hosted on Zoom and Facebook Live. Have questions or comments? Please reach out to hello@transformlexington.com.

This Project has been financed in part by the Maryland Center for History and Culture. However, the Project's contents or opinions do not necessarily reflect the views or policies of the Maryland Center for History and Culture.



October 17-December 6, 2020

Rights and Wrongs: Citizenship, Belonging, and the Vote

Saturdays-Sundays, 12pm-4pm, FREE

On view at Carroll Mansion, 800 E. Lombard Street

Reservations not required

Rights and Wrongs is an art exhibition that contends with the centennial of the 19th Amendment and the 2020 elections in light of the fact that equitable voter participation is hardly a settled matter in America — threats to citizenship, belonging, and democratic participation continue to be at stake. Local Baltimore artists Erin Fostel, Antonio McAfee, and McKinley Wallace III have created new artworks, related to the themes of racial, social, and economic injustice, and the various struggles for the vote. Some of their works respond to physical sites and visual records of contested public memory in Baltimore City.



Thursday, November 19, 2020 | 6:30pm-8:00pm

Virtual Artist Talk: Antonio McAfee, Erin Fostel, and McKinley Wallace III

FREE, Online

Join us for an online artist talk with local Baltimore artists Antonio McAfee, Erin Fostel, and McKinley Wallace III, presented in conjunction with the group exhibition, *Rights and Wrongs: Citizenship, Belonging, and the Vote*, at the Carroll Mansion.



Online Gala and Fundraiser

September 25, 2020

Recording available to Peale members. Please [contact us](#) for your link!

Despite the many challenges of 2020, there is still plenty to celebrate and a lot going on at the Peale. Join us September 25 for a special online event to catch up on the Peale's progress this year, see old friends and make new ones, all while supporting the preservation of our National Landmark building – an anchor institution in Baltimore for more than 200 years!



August 27, 4:00pm-5:30pm | FREE
Panel discussion: [Bridging the Digital Divide](#)

Join us for a panel discussion on bridging the "digital divide." Pre- and post-COVID, lack of access to the internet and digital resources is a major obstacle to inclusion for people living with disabilities and others. This panel discussion shares challenges, strategies, and solutions for bridging the digital divide from leaders who tackle this issue in their daily practice. Moderated by the Peale's Community Coordinator, Noreen Smith, the panel includes: Azure Grimes, Project Coordinator with Libraries without Borders; Dr. Nettrice Gaskins, artist and educator; Daisy Brown, Storytelling Ambassador and *Stoop Shoots* project lead at the Peale; and Debbie Staigerwald with The Arc Baltimore.



August 18, 11:00am-12:00pm | FREE
[National Park Service Suffrage Storymap Launch with Towson University](#)

The women's suffrage storymap, created by the National Park Service in collaboration with [Towson University and its Center for GIS](#), will go live on August 18 during a virtual launch event hosted by the Peale. The storymap sheds light on the key figures and networks of the women's suffrage movement using a new technology tool from the [National Park Service](#). This

launch event is being held on the 100th anniversary of the ratification of the 19th amendment, which granted women the right to vote on August 18, 1920.



August 15, 2020 | 11:00am-2:00pm
Founder's Day Celebrations | FREE
[Virtual Peale: Open House in Second Life](#)

The newest incarnation of the historic Peale Museum building opens on its 206th birthday as a full 3D virtual space in Second Life, hosting exhibitions, events, programs, and casual visits! Get a tour during our Founder's Day Open House or watch via livestream. Peale staff will be on hand at "Peale Museum Island" to welcome you and answer questions.



August 15, 2020 | 12:00-1:15pm

Part of the Redefine/ABLE Project | FREE

Panel Discussion: Accessibility and Inclusion in Physical and Virtual Spaces

Part of our Founder's Day celebrations and the Redefine/ABLE project and exhibition in the virtual Peale in Second Life, this panel discussion, moderated by Peale director, Nancy Proctor, responds to the challenges and opportunities of creating accessibility in both the physical and virtual worlds, particularly in historic structures - be they digital or "real." Panelists include George Ciscle, Curator-in-Residence Emeritus at Maryland Institute College of Art and founder and first director/curator of the Contemporary Museum, also known as The Contemporary; Alice Kreuger, founder of [Virtual Ability, Inc.](#); Monica Rhodes, Director of Resource Management, the National Park Foundation; and Dr. Jeremy Wells, Associate Professor in the Historic Preservation program in the School of Architecture, Planning and Preservation at the University of Maryland, College Park. Dr. Wells runs the web site, <http://heritagestudies.org>, which addresses ways of making historic preservation more human-centered.



August 14, 2020 | 2:00pm-3:00pm

Second Life's "Lab Gab" Show | FREE

Interview with the virtual Peale team

As part of Second Life's live-streamed variety show, "Lab Gab," on Friday, August 14th at 2pm EDT, the Peale's Executive Director, Nancy Proctor, and David London, Chief Experience Officer, discuss their collaboration with Eme Capalini from Virtual Ability, Inc. and the Linden Lab team to build the virtual Peale. Join us for an inside look into what it took to recreate the country's first purpose-built museum building in the internet's oldest and most populous virtual world during this special live event, which can be viewed on [YouTube](#), [Facebook](#), and on [Periscope](#).

REDEFINE / ABLE
CHALLENGING INACCESSIBILITY

July 29, 2020 | 4:30-6pm EDT

Rethinking Ability: A Community Storytelling Workshop

Free Online

Please join us for a virtual storytelling workshop with Mandla "Kosi" Dunn. Participants will work together and in groups to take inventory of their own abilities and explore basic elements of storytelling with the goal of developing a short written, audio, or visual narrative around any insights gleaned from the discussion. With permission, participants will have the opportunity to share their stories publicly on the Redefine/ABLE digital installation.



July 24, 2020 | 12:00pm

Panel discussion: How is Covid-19 redefining exhibits and inclusion?

Free Online

Panel discussion with Lara Perry (Deputy Head, School of Humanities University of Brighton), Beth Ziebarth (Director, Access Smithsonian), and Jeffrey Kent (Peale Artistic Director and Baltimore-based Artist)

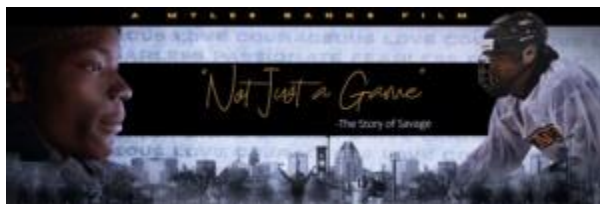

July 26 | 3pm - 4pm

Virtual Film Screening of *Not Just a Game-The Story of Savage*

Free Online

Check out a documentary about an ice hockey team of at-risk East Baltimore youth. The Peale and producers at Just Stunt Productions are debuting a mini-documentary, following one of the players through his first season and his growth on and off the ice. For the Banners, hockey is [#NotJustAGame](#). It's the feel-good story many of us need right now, so please join us. A panel discussion with the producer will follow.



July 1, 2020: 12:00pm

Online Screening of Ghost Tour, *Education Will Be Our Pride: The Colored School at the Peale* Online on our Website

Free online screening of “Ghost tour,” a virtual tour of the exhibit, *Education Will Be Our Pride: The Colored School at the Peale (1878-1889)*, followed by a panel discussion with some of the researchers who have been working on this part of the Peale’s history and the exhibition, including Tonika Berkley (Peale curator and educator) and Dean Krimmel (historian, museum consultant, and Peale board member).

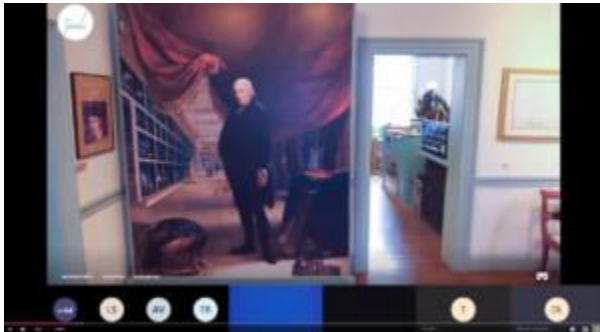

May 27, 2020 | 4:30-5:30pm

Highlights of the Peale: A Virtual Tour

\$5 in advance

Join us for a virtual tour of the Peale and its highlights! Hear some of the many stories of the building, from its origins as the first purpose-built museum in the country, to the introduction of gaslight technology to the city, to its role as Baltimore’s first City Hall and public high school for people of color. Get a glimpse of what is coming next as the Peale relaunches as a center for Baltimore stories and studies, and a laboratory for reinventing the museum for the 21st century in the creative and innovative spirit of the Peale family.



May 24, 2020 | 3:00-4:30pm

[Virtual Screening of *By Any Means Necessary: Stories of Survival*](#)

FREE

By Any Means Necessary: Stories of Survival (25 min.) takes a closer look at the young entrepreneurs that have grabbed both headlines and everyone's attention. Hear directly from them about the impact of squeegeeing on their lives and what they need the public to understand about this unique approach to self-sufficiency. Produced by the Baltimore National Heritage Area and presented by the Peale. The panel features



May 19, 4pm, 2020 | ONLINE

[Online Inclusion Webinar](#)

Join the Peale's accessibility expert Robin Marquis and other experts as she chats with online participants about the meaning and methodology behind inclusive design.

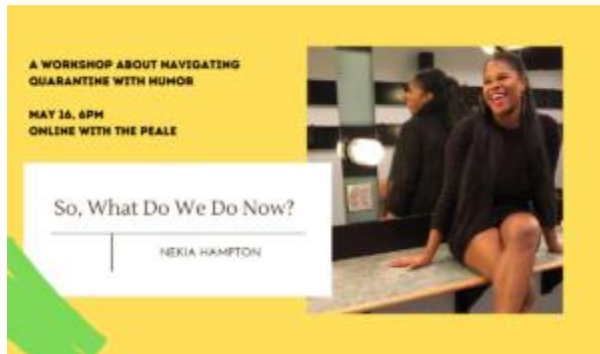

May 16, 2020: 6pm | ONLINE

So, What Do We Do Now? A Workshop with Nekia Hampton

Join Nekia Hampton and special guest Sheila Gaskins for a workshop on navigating life during quarantine while using humor to survive. In the workshop, Nekia will talk about ways laughter helps her get through the hardest days and offers tips to help others incorporate humor into their daily lives. Participants will also brainstorm what will replace the hug and the handshake in Baltimore and beyond in the post-quarantine world.



Friday, April 24 | 12:00 PM

It's More Than History ONLINE

Sylvea Hollis: *Creating A Usable Path for Women's Suffrage*

Mark your calendars for the Baltimore National Heritage Area's annual lecture series, co-hosted by the Peale Center. The theme is the *Year of the Woman*. In this lecture, Join Sylvea Hollis, a National Park Service/National Park Foundation Mellon Humanities Fellow, as she explores *Creating A Usable Path for Women's Suffrage*.



Fundraising for Storytellers during COVID-19
Wednesday, April 22, 2020 | 4:30pm

The Peale's capacity-building workshops for storytellers are back in a new, online format! Join local grant writer, Laura Wolf, on Wednesday April 22 at 4:30pm for a 20 minute overview of funding opportunities that have become available to help support Baltimore's storytellers through the financial crisis caused by the pandemic.



March 27, 2020 | 12-1:00pm
It's More Than History Lecture Series
Kacy Rohn: Remembering the Maryland Women's Suffrage Movement

Maryland women played an important role in the passage of the 19th Amendment. They organized, demonstrated, and campaigned for decades to win the right to vote, but their names and contributions have been forgotten or omitted from the historical record. Kacy Rohn will discuss her research she performed for the Maryland Historical Trust that provided new insight into the statewide suffrage movement and uncovered over fifty historic sites where women fought for voting rights. Many of these sites are concentrated in Baltimore, which served as a hub of statewide organizing and home to many prominent suffragists.



March 31, 2020, 3:30pm | [Online](#)

[Virtual Tour of the Peale](#)

In conjunction with the [MW20 Online conference](#), on March 31 we'll be offering a live virtual tour of the Peale with Executive Director Nancy Proctor and Chief Experience Officer, David London.

It's free! Just click the link you'll find in the [online program](#) to join from any browser.



March 5, 2020 | 5:30-6:30pm

[Reinventing the Peale: A Hard Hat Tour](#)

[Tickets: \\$10](#)

Join Baltimore Heritage for a behind-the-scenes tour of the Peale's renovations with architect Walter Schamu, and find out what is coming next as the Peale relaunches as a center for

Baltimore stories and studies, and a laboratory for reinventing the museum for the 21st century in the creative and innovative spirit of the Peale family.



Renovations: A Story of Edifice and Ecclesiastical Influences on 19th-Century African American Education

January 10-March 1, 2020 | Saturdays-Sundays, 12-4pm, FREE

The strikeWare Collective showcases traditional and new media to present a visual experience about the institutions, educators and progenitors who shaped how Baltimore's Black community acquired formal training and knowledge.

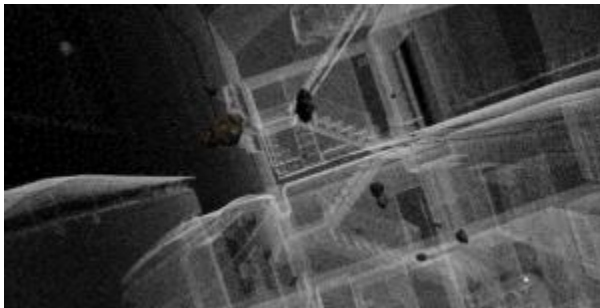

It's More Than History Lecture Series

February 28, 2020 | 12-1:00pm, FREE

***A View of 19th-century African American Education through the Lens of Contemporary Art* with Tonika Berkley, Dean Krimmel, Christopher Kojzar, Mollye Bendell**

Mark your calendars for the Baltimore National Heritage Area's annual lecture series, co-hosted by the Peale Center. In the kickoff lecture, hear from Tonika Berkley, research coordinator and curator at the Peale Center, as she talks about the history of African American education in Baltimore. Tonika will be joined by historian Dean Krimmel, Dr. Brian C. Morrison, and the artists behind the popular *Renovations* exhibition—Christopher Kojzar and Mollye Bendell.

Peale executive director Nancy Proctor moderates a panel discussion as well. *Additional lectures in this series will be held on March 27 and April 24.*



Renovations: A Story of Edifice and Ecclesiastical Influences on 19th-Century African American Education

**February 8, 2020 | 2:00pm-3:30pm | Gallery Talk
Carroll Mansion, 800 E. Lombard Street**

The strikeWare Collective showcases traditional and new media to present a visual experience about the institutions, educators and progenitors who shaped how Baltimore's Black community acquired formal training and knowledge.

Exhibition runs January 10-March 1, 2020. Open at the Carroll Mansion, Saturdays and Sundays, 12-4pm.



Simaetha: A Dreambaby Cabaret

January 17-19; January 24-26 | All shows at 8pm, except January 19 at 2:30pm

Tickets: \$10-\$65

SIMAETHA (pronounced sigh-mee-thuh) is an experimental witch cabaret written and performed by Jacob Budenz (a.k.a. Dreambaby), featuring dance and performance by Alexander D'Agostino. Through poetry, storytelling, music, and ritual, the show weaves together real and conjured memories, using mythology to rewrite identity.



Renovations: A Story of Edifice and Ecclesiastical Influences on 19th-Century African American Education

**January 10, 6:00-8:30pm | Exhibition Opening
Carroll Mansion, 800 E. Lombard Street**

The strikeWare Collective showcases traditional and new media to present a visual experience about the institutions, educators and progenitors who shaped how Baltimore's Black community acquired formal training and knowledge.



Leah Clare Michaels, "Melpomene & The Trinity of Mourning: Clean All the Stolpersteine"

October 26 - December 22, 2019

The Carroll Mansion, 800 E. Lombard Street

FREE | On view Saturdays and Sundays, 12-4 or by appointment

Leah, dressed in black, uses white rags to clean individual brass cobblestone memorials in Berlin and Rome that are dedicated to victims of the Holocaust. The memorials, called *Stolpersteine*, have been created by German artist Gunter Demnig since the early 1990s. As an American with European ancestry, including German and Italian, Leah's act of cleaning and mourning aims to: honor the individuals who were lost to the Holocaust and honor Gunter Demnig for starting and continuing his project.



Leah Clare Michaels, "Melpomene & The Trinity of Mourning: Clean All the Stolpersteine"
December 22, 3-5pm | Exhibition Closing
The Carroll Mansion, 800 E. Lombard Street
Free with Reservation

In each of the three pieces, Leah embodies Melpomene, Greek muse of sorrow and tragedy, creating a series of mourning rituals intended to draw awareness to personal and political social justice issues.

Exhibition runs through December 22. Open at the Carroll Mansion, Saturdays and Sundays, 12-4pm.



Workshop: Capacity-building for Storytellers with Genevieve de Mahy
December 11, 2019 | 7:00-9:00pm (Doors open at 6:30pm)
Carroll Mansion, 800 E. Lombard Street
Get FREE Tickets

Featuring Genevieve de Mahy, interdisciplinary theater artist, Single Carrot Theater, and a tutorial on intellectual property in the digital age. Location TBD. Funded by the [Baltimore](#)

National Heritage Area, PNC Bank, and an IMLS grant. Come early for drinks and meet other future storytellers.

This workshop will use performance techniques to explore verbal and nonverbal storytelling. Participants will use voice, movement, and physicality to delve into existing stories, embody their own stories and others' stories.

Strive Film Screening and Fundraiser

December 2, 5:30-9:00pm

Charles Theatre, 1711 N. Charles Street, Baltimore

Tickets: \$10-\$100

You are cordially invited to the December 2nd screenings of *By Any Means Necessary: Stories of Survival* and of *Strive*, the award-winning film launching on UMC this winter. The Peale is honored to help UMC bring this important story to Baltimore, a city teeming with young people striving against the odds to earn an education and a future since the Peale served as its first public high school for people of color (1878-1889).

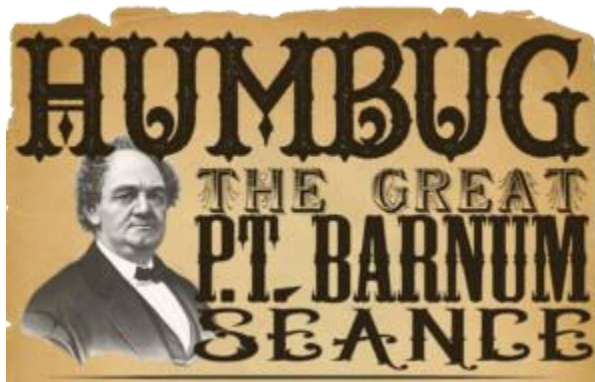

Humbug: The Great P.T. Barnum Seance

November 8, 9, 15, 16, 22, 23, 2019 | 8:00pm

The Carroll Mansion, 800 E Lombard St, Baltimore, MD 21202

Tickets: \$20-\$60 (Doors open 30 minutes prior to each performance)

Hear the incredible true stories of Barnum's life! Encounter genuine "artifacts" from Barnum's career! Witness the Fejee Mermaid! Experience Spirit Communication! Bring Barnum and his cast of characters back to life! Recommended for ages 16+.



Workshop: Capacity-building for Storytellers with Dr. David Fakunle

November 2, 2019 | 2:00-4:00pm

Great Blacks in Wax Museum Museum Mansion

1649 E North Ave, Baltimore, MD 21213

Get [FREE tickets](#)

Featuring Dr. David Fakunle, griot and master drummer, and a clinic on fundraising for storytellers – bring your questions about grants and more! Hosted at the National Great Blacks in Wax Museum Mansion. Come early for drinks and meet other storytellers.

This workshop has been made free thanks to support from [BOPA Free Fall Baltimore](#), the [Baltimore National Heritage Area](#), [PNC Bank](#), and a grant from the [IMLS](#).



The Camouflage exhibition by Sunhee Kim Jung

September 14-October 27, 2019

September 14, 2019 | 5-8pm: Opening reception

Sunhee Kim Jung's "The Camouflage" is the Peale's inaugural exhibition at its temporary residence, the Carroll Mansion. These large-scale paintings respect and honor the men and women who put their lives in danger serving in the U.S. Military. Soldiers are camouflaged in the battlefield to avoid physical danger and death, but they often camouflage their human emotions as well: the emotions of anxiety and uncertainty of their future and the longing to be home with their loved ones.



Closing Reception: The Camouflage Exhibition

October 26, 2019, 6-8pm: Closing Reception | FREE

Hear from Korean-born American artist Sunhee Kim Jung as she discusses her latest project, works in "The Camouflage" exhibition. Her large-scale paintings honor the men and women who put their lives in danger serving in the U.S. Military.



Jazz in Cool Places with Dr. John Lamkin

October 19, 2019 | 2-4pm

FREE!

Join us for an evening of incredible music by composer, musician, and educator Dr. John Lamkin in the courtyard of the historic Carroll Mansion. This concert is made free by the generous support of [Baltimore Office of Promotion & The Arts \(BOPA\)](#) Free Fall Baltimore, and [C & H Restoration](#).

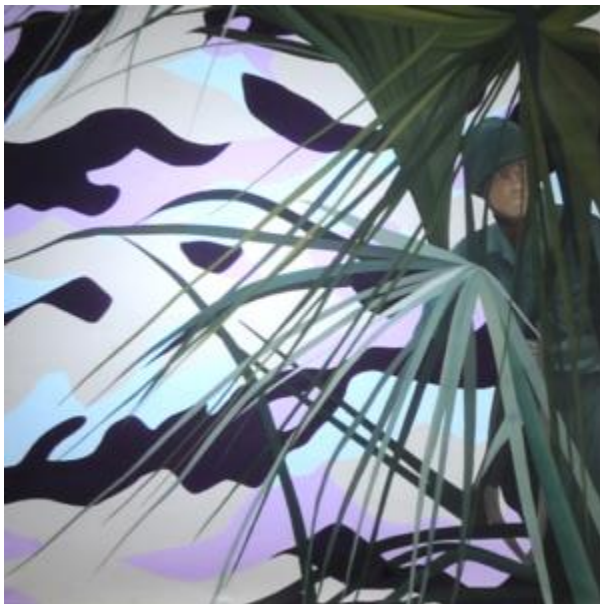

Artist's Talk with Sunhee Kim Jung

October 12, 2019 | 2-4pm | FREE

Exhibition runs September 14-October 27

Hear from Korean-born American artist Sunhee Kim Jung as she discusses her latest project, works in "The Camouflage" exhibition. Her large-scale paintings honor the men and women who put their lives in danger serving in the U.S. Military.



Workshop: Capacity-building for Storytellers with Aaron Henkin

October 17, 2019 | 7:00-9:00pm (Doors open at 6:30pm)

FREE

Join us for the first of several capacity-building workshops for storytellers! Learn from local grant writing experts how to raise money for your storytelling, and swap stories and storytelling tips with Aaron Henkin, producer of WYPR's *Out of the Blocks*. Uncover your storytelling skills and learn how to get grants for your storytelling practice in this free workshop series supported by [BOPA Free Fall Baltimore](#), the [Baltimore National Heritage Area](#), [PNC Bank](#), and a grant from the [IMLS](#).



***Education Will Be Our Pride: The Colored School at the Peale (1878-1889)* exhibition**

Through September 1, 2019

Opening Reception: June 19, 6-8pm

FREE, during our [usual opening hours](#).

On Juneteenth, Wednesday, June 19, the Peale proudly opens its newest exhibition that documents stories from the earliest years of public education for people of color in the State of Maryland and features artifacts, images, and documents related to "Male and Female Colored Grammar and High School No.1," housed in the Peale Museum building 1878-1889.



***Illuminated* exhibition**
Through September 1, 2019
FREE, during our [usual opening hours](#).

Illuminated sheds new light on the history and safety of gas and light. A multi-sensory journey, the Gaslight Tour also includes an 1816-style gas chandelier shining with “pearls of light” in the Picture Gallery and 19th-century gaslights in the historic garden.



***Adam Stab: STREET LIFE ART* exhibition**
Through September 1, 2019
FREE, with some ticketed events

ADAM STAB STREET LIFE ART is an uncomfortable acknowledgement of the experience of growing up and living on the streets where graffiti is made, and where others tend to avoid. This suite of artwork is inspired by the consideration of what it means to be a part of the world during this time of extreme polarization. Labels of ‘outcast’ and ‘outsider’ may be sought out and embraced by some, while adding to the already sizable burden of those born without

access to wealth, opportunity or privilege and subjugated to the lowest rungs of (American) society. This work is not pretty or vibrant as is a lot of graffiti and “street art.” It is literally trash.



Time Travel Tours

Through August 31, 2019 | Times Vary

Tickets: \$25 | By reservation only.

Email events@thepealecenter.org or call 1-866-TME-TRVL

After activating our 200-Year Time Machine, embark on a guided tour of Rembrandt Peale’s study in the year 1819.

Time Travel Tours are currently led by David London, a storyteller, historian and Certified Time Travel Agent, who will accompany you on your journey, and illuminate the many wonders you will encounter. Great for a group of friends!



Mash-ups: Creative Collaborations exhibition

August 9-31, 2019

FREE

Aiming to build bridges between audiences and creators in Baltimore’s arts scene, the “Mash-ups” exhibition features the work of three groups who were awarded grants to create storytelling projects with collaborators they had neither known nor worked with previously.



Adam Stab exhibition closing event

August 30, 2019 | 7-9pm

Tickets: \$15 in advance; \$20 at the door

Join us in the garden at the Peale Adam Stab with musical guests Judgemental and 209 Band, and the last chance to see STREET LIFE ART!



Cam's Sessions Concert

August 31, 2019 | 8:00pm (Doors open at 7:30pm)

Tickets: \$20 in advance; \$25 at the door

In the best of Baltimore traditions, enjoy an evening of swing, jazz, blues, and bebop with Cam Sterrett and the Camz Soundz & Vibrationz quartet. Featuring Cameron Sterrett on trumpet, Jeron White on bass, Yawn Jones on guitar, and Aggie Brown III on drums.

Doors at 7:30pm; concessions available before and during the show. Tickets \$20 at the door so save money by purchasing yours in advance!



Founder's Day Celebrations

August 15, 2019 | 4-9pm

FREE

Join us for our 205th birthday open house! Rembrandt Peale established the Peale Museum back in 1814. Come celebrate with us all afternoon and into the evening, with a storytelling studio, ongoing exhibitions, history of the building, virtual tours, time travel, and more!

Open House at the Peale, August 15, 4-9pm

- Show & Tell story recording with Mama Linda Goss
- Show & Tell Happy Hour, moderated by Aaron Henkin
- Mera Kitchen Collective documentary screening
- Time Travel Tours with David London
- Virtual reality tour of Devin Allen: Spaces of the Un-Entitled
- Submersive Productions open lab
- Silhouettes by Hand with Lauren Muney

Exhibitions on View:

- [Show & Tell: Baltimore Stories exhibition](#)
- Mash-ups: Creative Collaborations
- Adam Stab STREET LIFE ART
- Illuminated: A History of Gaslight
- Education Will Be Our Pride: The Colored School at the Peale



Submersive Productions: Institute of Visionary History: Project P.S.

August 14, 16, 23, 24, 25, 2019: Times Vary

Tickets: \$18-\$40

Project P.S. runs August 14th, 16th, 23rd, 24th, 25th. Subjects needed. Join in on procedures and extractions of metaphysical kurayami with a biomechatronic sculptor to examine the hypothesis that one can obtain enlightenment. Actualized by Mika Nakano, who first joined us for The Institute last year and more recently as a cast member in *MASS/RABBLE*. Tickets on sale in a couple weeks!



Adam Stab Storytelling event

August 21, 2019 | 6-8pm

Tickets: \$15 in advance; \$20 at the door

Adam Stab is Baltimore's longest-active graffiti writer. He has been both participant and formative to the culture of Style Writing since 1984. Since the mid-eighties the movement of style writing (or graffiti writing) has become the largest, fastest growing artform – or rather culture – on the planet.

Please join us in discussing Adam Stab's process and lifestyle as a world renowned graffiti artist. Adam would like to converse with you, to discuss the trials and tribulations of some parts of the Baltimore city, and how his art is promoting the Street Life in a creative and positive direction.



Blaqstarr Gassed 'N' Electriq Party

August 10, 2019 | 8pm-12am

In the Peale garden

Tickets: [RSVP for FREE!](#)

Internationally known, Baltimore based DJ, Producer and Recording Artist [Blaqstarr](#) presents a brand-new artsy dance party illuminating eclectic sounds and visuals by Baltimore's best, cutting-edge artists. Co-produced by [Invisible Majority](#). Find the producers on social media [@blaqstarr](#) and [@imajoritybmore](#).



An Elegant Rendezvous with Scott Patterson

August 8, 2019 | 7-10pm (Champagne toast begins at 7pm; Concert begins at 8pm)

Tickets: [\\$27-\\$37](#)

Explore the alien landscape of 25th century music with composer, pianist and Baker Artist Awardee, Scott Patterson. His compositions for solo piano pulse with future forward melodies that incorporate the classical, soul and rock music of our present day and generations to come.

You can purchase [tickets from artful.ly](#), OR you can go solo with our friends at [Mixolo](#). Learn more about Mixolo here: <https://www.mixolo.io/>



Decades Nightclub: A Celebration of the Black Club Experience in Baltimore from the '80s-'00s exhibition

June 28 - August 11, 2019

Opening reception: June 28, 7-9pm

FREE, during our **usual opening hours**.



The Yellow Wallpaper play

August 2 & 3, 2019 | 8:00pm

Tickets: **Sliding Scale, \$10 - \$50**

Welcome Homesick presents *The Yellow Wallpaper*

By Charlotte Perkins Gilman

Adapted for the stage by Aziza Afzal

Local Maryland theater collective Welcome Homesick Productions returns this summer with their latest play, *The Yellow Wallpaper*. The play is an original adaptation by Welcome Homesick co-founder Aziza Afzal, and is based on the Charlotte Perkins Gilman 1892 novella by the same name. It is directed and performed by Welcome Homesick co-founders Aziza Afzal, Emma Bergman, Sophie Cameron, Meg Lebow, and Clare Lefebure, with movement direction by Alayna Baron and original sound by Sam Dembling.



Adam Stab Live Painting

July 24, 2019 | 7pm

Musical accompaniment by Ronald Rucker's Electronic Art

Tickets: \$15 in advance; \$20 at the door

When Adam Stab first moved to Baltimore in 1983 he was 13 years old, without siblings or friends, alone and a loner. He was drawn to the streets, plunging into its depths on his skateboard, into alleys so deep they became urban canyons, a webbing of traverses opening to infinite possibilities for a kid searching for himself in a concrete jungle. It was in this state of search and discovery that Stab found the "heat (he) had never known, a first full breath of passion" never inhaled before.

Please join us for a night of new art brought to The Peale by world renowned graffiti artist, Adam Stab. We ask that you and your friends bring enthusiasm to the space, as well as a couple of questions for the artist at the end of his performance.



***The Yellow Wallpaper* play**

July 26 & 27, August 2 & 3, 2019 | 8:00pm

Tickets: Sliding Scale, \$10 - \$50

Welcome Homesick presents *The Yellow Wallpaper*

By Charlotte Perkins Gilman

Adapted for the stage by Aziza Afzal

Local Maryland theater collective Welcome Homesick Productions returns this summer with their latest play, *The Yellow Wallpaper*. The play is an original adaptation by Welcome Homesick co-founder Aziza Afzal, and is based on the Charlotte Perkins Gilman 1892 novella by the same name. It is directed and performed by Welcome Homesick co-founders Aziza Afzal, Emma Bergman, Sophie Cameron, Meg Lebow, and Clare Lefebure, with movement direction by Alayna Baron and original sound by Sam Dembling.



Never Normal Records Presents: NNECESSARY | Live in Baltimore

An Electro Music Showcase

July 27, 3-6pm, 2019

Tickets: [\\$7 general admission](#)

Join us for a look at the Decades Nightclub exhibition, a music showcase, and delicious food! [NNECESSARY](#) is a new monthly producer/musician + art experience presented by Suzi Analogue's Never Normal Records. At NNECESSARY we connect music creators & creative lovers in a setting to discover exciting new music and visions from the world of Never Normal beyond a club setting. Find [NNECESSARY on Spotify](#) as well.

- Featuring ZIGGEE GOLD, STATION NORTH SADBOSI, JWORDS, NAPPA NAPPA, SO NICE YESTERDAY
- A SPECIAL PRESENTATION by BLAQSTARR
- IN PARTNERSHIP WITH 'DECADES NIGHTCLUB' EXHIBIT



Cam's Sessions Concert

July 27 | 8:00pm (Doors open at 7:30pm), 2019

Takes place off-site at the Carroll Mansion, 800 E Lombard St, Baltimore, MD 21202

Tickets: [\\$20 in advance](#); [\\$25 at the door](#)

In the best of Baltimore traditions, enjoy an evening of swing, jazz, blues, and bebop with Cam Sterrett and the Camz Soundz & Vibrationz quartet. Featuring Cameron Sterrett on trumpet, Jeron White on bass, Yawn Jones on guitar, and Aggie Brown III on drums.

Doors at 7:30pm; concessions available before and during the show. Tickets \$20 at the door so save money by purchasing yours in advance!



Submersive Productions: Institute of Visionary History: Altar Ego

July 6 & 7, July 17, 20, 21, 2019

Tickets: \$15-\$40

Five dates only! Staggered entry times. Be sure to arrive 15 minutes prior to your scheduled entry time. Altar Ego is a completely self-contained 45-60 minute multi-sensory experiences for a group of up to five people. You are invited to a unique house party to learn more about your "model citizen" Vietnamese-American neighbor, and explore the boundaries between home and not home. (Actualized by Kim Le.)



***Forced Intimacy: A Millennial Vignette on Baltimore Party Culture* exhibition**

June 28 - July 14, 2019

Opening reception: June 28, 7-9pm

FREE, during our usual opening hours.

Join us on a journey through time to an imaginary Baltimore nightclub in the 80's - 00's. Experience and contribute to an evolving crowd-sourced installation collecting and sharing stories about Black club life in Baltimore.



Blaqstarr Gassed 'N' Electric Party
Saturday, July 13, 2019 | 8pm-12am
In the Peale garden
Tickets: \$15 in advance; \$20 at the door

Internationally known, Baltimore based DJ, Producer and Recording Artist [Blaqstarr](#) presents a brand new artsy dance party illuminating eclectic sounds and visuals by Baltimore's best, cutting-edge artists. Co-produced by [Invisible Majority](#). Find the producers on social media [@blaqstarr](#) and [@imajoritybmore](#).



Hugo Ball: A Dada Garden Party
July 14, 2019 6-9pm |
Tickets: \$15-\$25

Artist Hugo Ball first read his Dada Manifesto on July 14, 1914 at the first Dada Soiree in Zurich. Join us on the 105th anniversary of the birth of Dada to celebrate this anti-art movement, which gave rise to the avant garde. The Hugo Ball will be held in the historic garden at the Peale, and will feature amusements, delights, and wonders and surprises. Dada or Surrealist attire is strongly encouraged.

“Why can't a tree be called Pluplusch?”
— Hugo Ball



Chit Chat: A Conversation about Baltimore Queer Nightlife and After Party

July 10, 2019

7-9pm: Panel Conversation

9pm-Midnight: After party and visuals with Dj Genie & Levity

Tickets: \$10 panel, \$10 party, \$15 both

Hosted by Levity artist's Perri B.B & Alejandra Nuñez. The panel will feature artists and organizers from the Baltimore queer scene specifically DDm, Kotic Couture, Trillnatured, Randi misfit, hunter hooligan, & Baby. Panelists have all played a unique part in shaping the scene we have today.

After party and visuals with Dj Genie & Levity.



The History Behind Hamilton: from Battlefield to Broadway

Talk with Mary Blair and Burt Kummerow

Presented by Maryland's Four Centuries Project

June 29, July 12, July 14, 2019

FREE with RSVP

Who was the man who inspired the award-winning, supremely hip musical? How was Hamilton linked to Washington? Was he an abolitionist? What about the duel with Aaron Burr that led to his death? If you can't see the play, or if you want to see what was fact and what was fiction in the performance, come and learn the real history of Alexander Hamilton and his tumultuous life, as explored through questions and answers with historians.

If you are going to see the play, this talk will make the politics and history much clearer!



Cam's Sessions Concert

June 29, 2019 | 8:00pm (Doors open at 7:30pm)

Tickets: \$20 in advance; \$25 at the door

In the best of Baltimore traditions, enjoy an evening of swing, jazz, blues, and bebop with Cam Sterrett and the Camz Soundz & Vibrationz quartet. Featuring Cameron Sterrett on trumpet, Jeron White on bass, Yawn Jones on guitar, and Julian Berkowitz on drums.

Doors at 7:30pm; concessions available before and during the show. Tickets \$20 at the door so save money by purchasing yours in advance!



Baltimore Enters the Industrial Age: Lecture with Jack Burkert

June 28, 2019 | 12:00 noon

FREE

Presented by the [Baltimore National Heritage Area](#)

When the 19th century opened, a few villages destined to become Baltimore were modest centers of trade. Dependent on Europe for both trade and financing, these villages left behind, slowly at first, their agrarian roots as the new century matured. Immigrants flowed in, village centers merged and Baltimore became an important business and industry center. Ores, coal, wheat, cotton and of course, in the midst of it all, the humble oyster became king. Baltimore

was “oyster town” with its hundred packing-houses lining the waterfront. Shipbuilding, shipping companies, then railroads each had and have a continuing role in making Baltimore an important center for commerce.



Time Travel Tours

June, 2019 (ongoing)

Friday-Sundays, or by appointment

Activate our 200-year Time Machine and embark on a guided tour to Rembrandt Peale's study in the year 1819! Time Travel Tours are led by curator, storyteller, historian and David London, who will accompany you on your journey, and illuminate the many wonders that await you inside.

Each Time Travel Tour includes the history of the Peale family and their museums, an introduction to our Time Machine, and up to 40 minutes of actual Time Travel! Time Travel Tours are ideal for 2-10 guests, and there are several tour options for your to choose from.



An Elegant Rendezvous with Joyce J. Scott: An Evening of Song and Stories

Friday, June 21, 2019 | 8pm (doors open at 7:30pm)

VIP champagne toast with Joyce Scott at 7pm

Tickets (\$50-\$100) to benefit the Peale

Joyce J. Scott, world-renowned artist, educator and vocalist, launches the new *Elegant Rendezvous* series at the Peale. The series features Baltimore area creators and innovators

sharing their work and stories. A Baker Artist Awardee and Macarthur Fellow, Joyce is well known for combining her variety of artistic skills with social commentary on issues such as racism, classism, sexism, violence, and cultural stereotypes.



No Walls, No Bans, No Borders

May 9 – June 2, 2019 | FREE during our **usual opening hours**.

June 1, 6pm-9pm

Closing Reception with music from Que Pequeno and a performance by Conjunto Bruja

No Walls, No Bans, No Borders is a benefit photography and art exhibit featuring the work of Baltimore-based activists connecting ideas of the violence of capitalism, colonialism, and the racist/fascist state both locally here in Baltimore and globally. A portion of artist's sales will go back to the groups doing the work on the ground. The theme focuses on the work being done to dismantle walls/bans/borders of oppression, whether through physical state walls, walls of a prison, walls of stigma, or institutional walls. This exhibition tell the story through the eyes of those on the ground doing the work.



Historically Hysterical

April 11-28, 2019

FREE during our **usual opening hours**.

Maryland Institute College of Art's (MICA) Exhibition Development Seminar (EDS) presents

historically hysterical, a show featuring artists who reject the coercive hierarchy of gender roles in order to smash the patriarchy. Created by a class of twelve women curators, the exhibition uses installation, performance, photography, and mixed media fiber works—all created by contemporary women artists—to transform three floors of Baltimore’s historic Peale Center. Image: *The Effect of the Whole*, by Tamar Stone, 2012-2015.

Maryland Institute College of Art’s (MICA) Exhibition Development Seminar (EDS) presents historically hysterical, a show featuring artists who reject the coercive hierarchy of gender roles in order to smash the patriarchy. Created by a class of twelve women curators, the exhibition uses installation, performance, photography, and mixed media fiber works—all created by contemporary women artists—to transform three floors of Baltimore’s historic Peale Center. Image: *The Effect of the Whole*, by Tamar Stone, 2012-2015.



[A Night of Light: Ceremonial Lighting of the New Ring of Fire](#)

April 24, 2019 | 5:30pm -8:30pm

FREE.

[RSVP here!](#) Light artist Sean Michael Kenny (SMKLight) is collaborating with the Peale Center for Baltimore History and Architecture to help people “see Baltimore in a new light” by illuminating Baltimore’s 19th origins as “Light City” and bringing greater visibility to the city’s diverse cultural stories and voices today. Kenny’s latest work for the front porch of the historic Peale Museum building on Holliday Street in downtown Baltimore reimagines the “Magic Ring of Fire” gaslights that Rembrandt Peale first demonstrated in his museum in 1816.



Cam's Sessions IV: Concert

April 27, 2019 | 8:00pm (Doors open at 7:00pm)

Tickets: \$20 in advance; \$25 at the door

In the best of Baltimore traditions, enjoy an evening of swing, jazz, blues, and bebop with Cam Sterrett and the Camz Soundz & Vibrationz quartet. Featuring Cameron Sterrett on trumpet, Jeron White on bass, Yawn Jones on guitar, and Julian Berkowitz on drums.

Doors at 7:30pm; concessions available before and during the show. Tickets \$20 at the door so save money by purchasing yours in advance!

It's More Than History Lecture Series

February 12- April 12, 2019, 12:00-1:00 pm

FREE

The Baltimore National Heritage Area presents the lunchtime lecture series, "It's More than History," at the Peale from February – April 2019. All talks are from 12:00-1:00pm and are free (lunch not provided). Bring your lunch and join us!



Potables from the Past

March 2, 2019: 6-9PM

Tickets from \$25-\$35

Join us for a very special **Time Travel** event to support the Peale Center. The evening will feature amusements, entertainment and beverages from 1819, along with many surprises.



YARROW MAMOUT IN BALTIMORE

Yarrow Mamout in Baltimore: Lecture and Panel Discussion

March 2, 2019 | 2-4PM

FREE, with a \$10 Suggested Donation to the Peale Center

In 1819, Yarrow Mamout was an 84 year old craftsman, land-owner, financier and devout Muslim, who made his home in Georgetown after enduring over 40 years of slavery. Born in Guinea in 1736, he was enslaved and brought to Maryland at just 16 years old, and after gaining his freedom, became well-known and respected for his entrepreneurship, work-ethic, and cheerful spirit.

Join us for a panel discussion to explore the incredible life of Yarrow Mamout, the significance of this painting, and the history of Muslims in America in the 19th century. Stay for a 4PM Time Travel Tour at the Peale for an additional \$20. Limited to 12 guests. More info at www.time-travel.tours

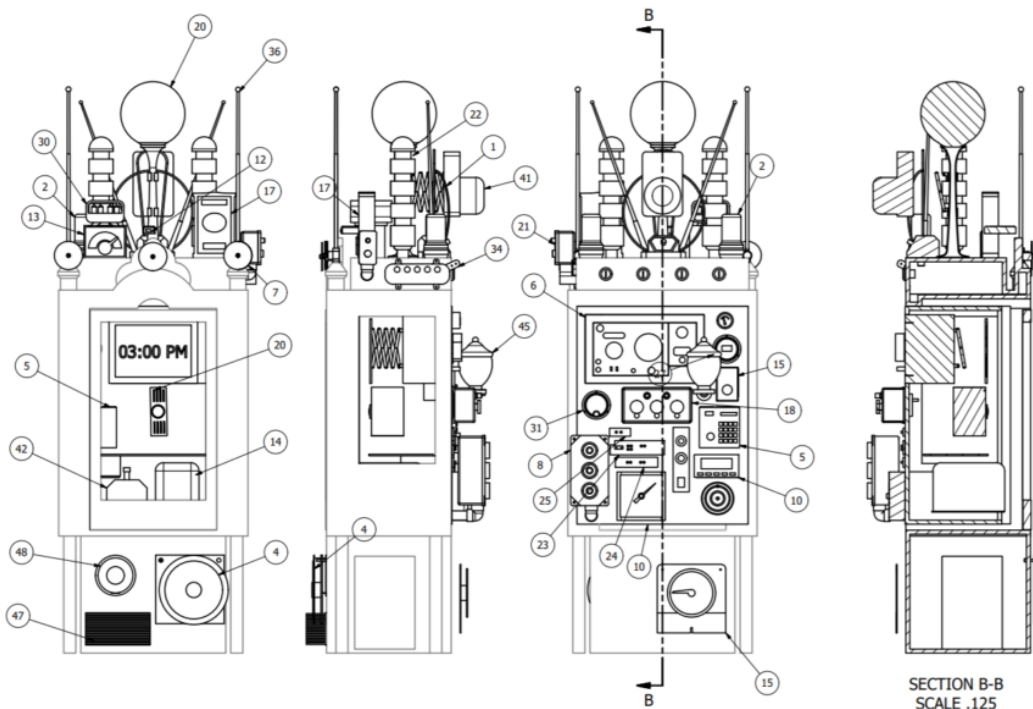

Time Travel Tours
Thursdays – Sundays

Remaining dates: February 23, 24, 28; March 1, 2, 3, 2019

Buy Tickets: [\\$15-\\$25](#)

After receiving detailed plans from future time travelers, the Peale has constructed a 200-year time machine, and is pleased to now offer Time Travel Tours to Rembrandt Peale's study in the year 1819.

After activating the Time Machine, guests are invited to step back in time to enjoy a guided tour of this hands-on exhibit led by curator, historian and storyteller David London, who will illuminate the many wonders that await you inside. Each 90-minute experience includes up to 40 minutes of actual time travel.

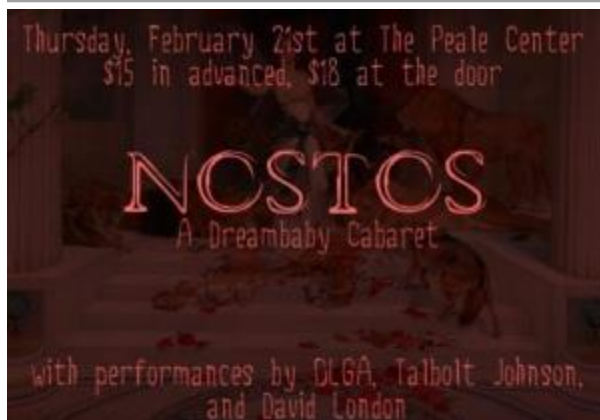

[NOSTOS: A Dreambaby Cabaret](#)

Thursday, February 21, 2019

8:00 PM – 10:00 PM

Doors open at 7:30 PM

\$15 Advance // \$18 at door

Tickets: dreambabinostos.brownpapertickets.com

The Ancient Greek term NOSTOS refers to those stories in which someone returns home after a long journey filled with perilous obstacles, often by sea, in the hopes of reclaiming what was once their own. NOSTOS: A Dreambaby Cabaret is a homecoming show produced by Dreambaby, Baltimore's favorite (and only) witch cabaret musician.

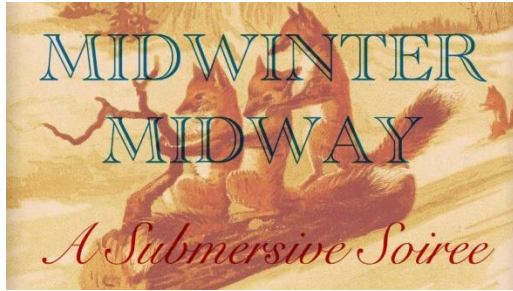

Fundraiser: Midwinter Midway | A Submersive Soiree

February 9, 2019, 7:00pm-10pm

Buy Tickets , starting at \$25

Help us fight the dulling doldrums of winter! For one night only (Saturday February 9th, 7pm-10pm) Submersive Productions, LLC, is throwing a party at The Peale Center, featuring a dazzling display of entertainments a la vaudeville. The incomparable talents of Alex & Olmsted will join your favorite performers of past Submersive productions to captivate, charm, and enthrall you with their diverse talents.



Devin Allen: Spaces of the Un-Entitled

A visual analysis of architecture and its impact on people of impoverished communities

February 7, 2019 – March 22, 2019

“Stay dangerous,” a motto coined by D. Watkins, describes Devin Allen’s approach to artistic life and philosophy, and the impetus of his work in *Spaces of the Un-Entitled*. “Stay dangerous” is a challenge and a promise. It means that if you have the strength and daring to be honest in your experience of and interaction with the world, you can count on two things- Your strength will demand respect, and Your honesty will be a danger to those who live and profit by refusing it- and consequently, a danger to you. As you refuse to yield, you prove you have the strength to back up the danger of honesty. The more you stay dangerous, the more dangerous you become to the status quo.



Cam's Sessions

Saturday, Jan 26, 2019 | 8-10pm (doors 7:30pm)

Buy Tickets \$15 in advance/\$20 at the door.

In the best of Baltimore traditions, enjoy an evening of swing, jazz, blues, and bebop with Cam Sterrett and the Camz Soundz & Vibrationz quartet. Featuring Cameron Sterrett on trumpet, Jeron White on bass, Yawn Jones on guitar, and Julian Berkowitz on drums.

Doors at 7:30pm; concessions available before and during the show. Tickets \$20 at the door so save money by purchasing yours in advance!



New Beginnings: An Evening of Baltimore Stories at Spotlighters Theater

This event is off site at Spotlighters Theater. Curated by The Peale Center

Friday, Jan 25, 2019 | 8-10pm

Buy Tickets \$20

As the new year starts, we celebrate new beginnings in Baltimore with a special storytelling cabaret curated by the Peale Center for Baltimore History and Architecture and hosted by WYPR's Aaron Henkin, producer of *Out of the Blocks*, with Jessica Myles Henkin from *The Stoop* and Nate Couser of *The Artist Exchange Radio Show*. Hear some of Baltimore's best storytellers from leading local storytelling organizations as they share their stories of personal and urban

renewal. Add your voice to the soundtrack of the city by helping interview participants and contribute your own authentic story in the open mic portion of the program!



December 23 , 2018 | 9am-3pm

The Sunday Makers' Market

FREE

Discover workshops and original creations from local artists and makers! If you are interested in running a workshop or selling your work at The Peale Center, please stop by during our [visiting hours](#) or complete [this form](#) to let us know a bit more about you and your work! Feel free to [reach out with any questions](#).



Episode Six: December 8, 2018

The Institute of Visionary History and the Archives of the Deep Now

Buy Tickets: \$15-45

The wondrous, boundary-stretching 8-hour Renaissance fever dream that is Episode Six of the Institute of Visionary History returns by popular demand December 8th to the Peale! [More details](#).



Episode Five: December 8, 2018

[The Institute of Visionary History and the Archives of the Deep Now](#)

Buy Tickets: [\\$15-45](#)

From the creators of *H.T. Darling's Incredible Musaeum!*, a new immersive experience from [Submersive Productions](#). Participants are invited to unravel the mysteries of a centuries-old secret society and their uncanny methods for re-visioning new histories heretofore untold. Each experience runs 30-45 minutes for a group of about five people. [More details.](#)

November 14 - December 16, 2018

Baker Artists [OFF THE WEB Exhibition](#)

Opening Reception: WEDNESDAY, November 14th, 6pm - 9pm Over 100 Baltimore Area artists bring some of the regions newest art to the oldest museum building in America! FREE and open to the public! On display through December 16, 2018. [More details.](#)

November 28 | Doors and tours at 7:00pm; show 7:30pm

2018 Storytelling Showcase

Buy Tickets: [\\$50 to benefit the Peale's Fall 2018 Campaign](#)

Support the Peale and celebrate the close of our Fall capital campaign initiative with a special evening of authentic Baltimore stories hosted by WYPR's Aaron Henkin, producer of the award-winning [Out of the Blocks](#) series, and Nate Couser of [The Artist Exchange Radio Show](#). Tour the historic Peale Museum building and explore installations and immersive theater vignettes from recent productions at the Peale, and an exhibition of work by Baker Award-winning artists.

Free parking at Zion Church and complimentary Peale cocktail with dinner at Ida B's before the show!



November 2-4, 2018 | Various Times
Day of the Dead/Día de los Muertos Celebrations

Tickets: FREE

Join the Smithsonian Latino Center at the Peale Center in a celebration of life and death. Walk the path of the spirits, participate in art installations by Latino artists, explore different Day of the Dead/Día de los Muertos cultural practices, and learn about the legend of la Llorona, our highlighted mythological figure.



October 26-31, 2018 | Shows at 7:00pm and 9:30pm
Lurid Happenings: A Night of Devilry & Mischief

Buy Tickets: \$20 and up

Join the Baltimore Rock Opera Society for a very special Halloween performance!

An evening of magic, macabre, and mystery await you at Lurid Happenings: A Night of Devilry and Mischief! The Amazing Allerdyce and his peculiar assistant Sinifredo, recently returned from a globe-trotting exploration of the dark arts, will regale you with marvelous acts of prestidigitation, test your fears, and perhaps even provide a little guidance from the spirits just beyond your vision.

Following Allerdyce's magical display, those whose minds are still intact are invited to reflect on their experience and enjoy a festive Halloween party surrounded by artifacts from Baltimore's history and architecture in The Peale Center with drinks, live music, and haunted interactive experiences. Guests will enjoy the music of Quattrocanta on 10/26 and 10/27, Voodoo

Pharmacology on 10/28 and TBD on Halloween Night. This after party will be available to attendees of both performances between the first and second show from 8:15 - 9:45 PM.



October 28, 2018 | 12:30-3:00pm

Build a Bee House: Workshop with Ashley Kidner

Buy Tickets: [\\$25 includes materials](#)

Learn how to build bee houses and motels for our native bees and wasps and take home your own solitary bee house! 15 participants are required for the workshop to run, with a maximum of 25.



October 28, 2018 | 1:30-2:30pm

Storytelling Session with Mama Linda Goss and David Fakunle!

Tickets: FREE

Drop-in to hear Mama Linda Goss, Storyteller-in-Residence at the Peale, and Master Drummer and Storyteller, Dr. David Fakunle, share stories about bees, butterflies, and more inspired by the Peale's pollinator garden. This program is part of [Free Fall Baltimore](#). Check out [Mama Linda, Brother David, and other storytellers at the Peale](#) from earlier storytelling sessions.



October 21, 2018 | 1:30-2:30pm

Free Storytelling Workshop with Mama Linda Goss and David Fakunle!

Join Mama Linda Goss, Storyteller-in-Residence at the Peale, and Master Drummer and Storyteller, Dr. David Fakunle, for a free session of story swapping and rhythm talking. [Places are limited so RSVP](#). Part of [Free Fall Baltimore](#)

[Hear Mama Linda, Brother David, and other storytellers at the Peale](#) from earlier sessions.



September 16 - October 15, 2018

[Architecture/Baltimore](#)

[Thu-Sat 6-10pm; Sun 9am-5pm & by appointment](#)

Wed 26 Sept: Reception, 6-8pm; Talk by Steve Ziger, 6:30pm

Sun 7 Oct: Artists' Talk, 12-1pm Sun

Free admission with suggested donation to reception and talks.

Photographs of places of Baltimore's worship, museums, schools, breweries, theaters, galleries, historical sites, converted industrial structures, and more by Vivian Doering, Brian P. Miller and Andrew Nagl, made in cooperation with the Baltimore Architecture Foundation and AIA Baltimore for [Doors Open](#).

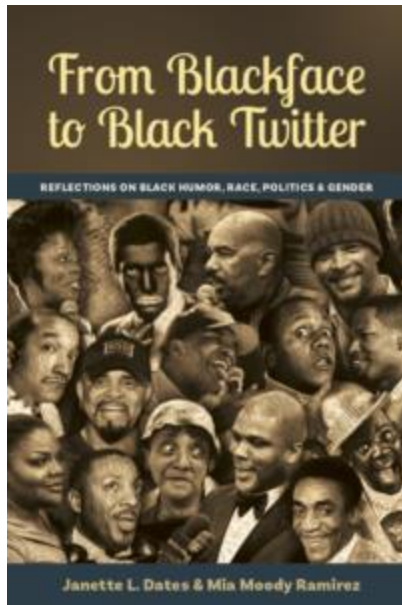

Sunday, October 7 | 2-4pm

Book launch: From Blackface to Black Twitter

Free, [RSVP](#)

Meet the authors and get a signed book!

[Buy your copy here](#) or purchase one at the event.

"The major contribution of this book is in the authors' very timely and important explication of the impact of new social media platforms on the deployment of black humor in the early 21st century, by both professional comedians and by the general public." *—Henry Louis Gates, Jr., Alphonse Fletcher University Professor and Director of Hutchins Center*



Thurs-Sat, October 4-6 | 8:00 pm

Afro Punk Ballet

Tickets \$15 & up

The latest ground-breaking production from [Afrohouse](#), *Afro Punk Ballet* is an exploration of the crossroads between African spirituality, mathematics, and physics, poetically weaving “time and space” within the movement and music.



Friday, September 7 | 8pm (doors open 7:30pm)

[Wasted](#)

Tickets \$25/\$20

Presented by Baltimore Center Stage in partnership with the Peale, [Wasted](#) explores consensual sex and what can happen when lines, and memories, are blurred. Award winning Irish writer and director Kat Woods presents a completely original theatrical experience like no other play that you will see in Baltimore this fall.



August 9, 10, 11, 16, 17, 18, 23, 24, 25, 2018 | 19:24 (7:24pm)

[Illuminated \(A Surrealist Garden Party\)](#)

Limited to 30 guests. Admission: \$11 - \$55

[Book tickets here.](#)

Amusements, delights, and wonders will be provided. Featuring fantastic feats from a rotating cast of curious characters. Recommended for all children over the age of 21. Upon the occasion of rain, snow or locusts, festivities will be relocated indoors.



August 15-19, 2018
Founder's Day Celebrations
[Full Schedule](#)

Rembrandt Peale first opened the doors to his Museum and Gallery of Fine Arts in Baltimore on August 15, 1814. We're celebrating the Peale's birthday August 15-19, 2018. Highlights include:

- **Wednesday, August 15th:** Lunchtime talks and tours of the Peale's historic gaslights and garden, followed by silhouette cutting and an a cappella concert in the best acoustic space in Baltimore 6-9pm!
- **Thursday, August 16th:** All day tours of the Peale for artists and performers looking for unique rental and event space. [Book yours now!](#) At 19:24 (7:24pm), be "illuminated" at the Surrealist Garden Party.
- **Friday, August 17th:** Authentic *Be Here: Baltimore* stories with Nate Couser's [Artist Exchange Radio Show](#) broadcasting live from the Peale at noon. *Illuminated*, a Surrealist Garden Party at 19:24 (7:24pm).
- **Saturday, August 18th:** At 2pm, *Before Hollywood: Philadelphia and the Birth of the Movies* film screening and panel discussion with the director, co-producer, and contributors. *Illuminated*, a Surrealist Garden Party at 19:24 (7:24pm).
- **Sunday, August 19th:** 9am-3pm Makers' Market. 12-1pm Artist's talk: What is Surrealism? with David London. 6-8pm Words, Wine & Wings "4" Poetry Show.
-



Sunday, July 22 & 29, 2018 | 2pm
[Storytelling with Mama Linda Goss](#)

Join Mama Linda Goss, Storyteller-in-Residence at the Peale, for a free session of story swapping and rhythm talking. Places are limited; [RSVP](#).

[Hear Mama Linda and other storytellers at the Peale](#) from earlier sessions.



Volunteer to Help Plant!
Saturday 21 July 9:30am-12:30pm

The renovations of the Peale's historic garden are complete. Now help us finish the planting of the Peale's Pollinator Garden! [RSVP](#)

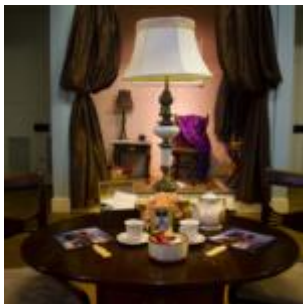

June 28-June 30, 2018, 12pm-6pm
July 1, 10am-4pm
BootPrints Exhibition: Standing Room Only

Standing Room Only, part of the BootPrints suite of experiences that includes an immersive theater and a film (see below), is curated by [Tiffany Jones](#) and features work by [Brianna Faulkner](#), [Antonio McAfee](#), and I Henry Phillips Sr. The exhibition will accompany the production of the film and will be on display at the Peale Thursdays, Fridays, and Saturdays. Each artist's contribution guides us on a visual trajectory as we learn about one woman's journey home. Free during the Peale's [opening hours](#).



June 30, 2018, 6pm

[BootPrints Immersive Performance](#)

Includes staged reading with live chorus, immersive exhibition, and conversation between the playwright, Latonia Valincia-Moss and Angela Carroll of [BmoreArt Magazine](#), as well as a vegan tasting. Drinks can be purchased additionally during the event. **Tickets are \$15 in advance and \$20 at the door.**



May 11-20, 2018

[Pealed Every Which Way](#)

An exhibition of site-specific works, sounds, performances and stories that respond to the Peale Museum building and history by Goucher College students. The works were created as part of an “extended-looking” exercise conducted at the Peale over the past semester in Professor Laura Burns’ course *The Art of Observation*. **[More information.](#)**



May 18, 2018
Say It Loud Film Festival

Say It Loud is a free Festival of local poets, local musicians, and both local/international short films that takes place during the springtime at the Jubilee Arts Center in West Baltimore, in addition to the Peale Center in downtown, and during Artscape on the 52' tall LED Baltimore digital billboard next to Penn Station. Our intention is simple: unite, engage and inspire artists and audience members all over the world through one common goal – to transform the narrative of pop culture. [More information.](#)



May 11-13, 2018
Tolbert D'Agostino Dance presents *Grandmothers*

A dance exhibition that pays homage to, reflects and honors the tremendous lessons from generational protectors both met and unmet: our grandmothers. [More info and tickets here.](#)

Performances: May 11th & 12th at 8pm; May 13th at 2pm. **Dancers:** Noelle Tolbert; Alexander D'Agostino; Alyana Baron; Lindsay Chestnut; Sabrina Liu. The exhibition will also be on view Saturday May 12th from 12-6pm and Sunday May 13th from 10am-4pm. Our vision is strong and we believe that we can make this project happen with your help! PLEASE SUPPORT US AS INDEPENDENT ARTISTS by following the link to our [Kickstarter campaign](#).

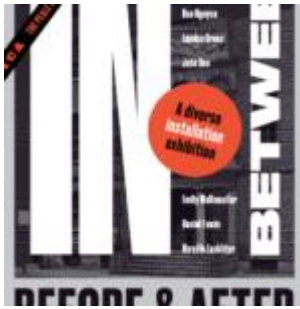

May 4, 2018

[In Between Before & After](#)

An exhibition of site-specific installation work by student on the B.F.A course in [Interdisciplinary Sculpture at MICA](#), including ReAnn Orr; Pierce Henderson; Nicole Fleming & Vlada Dyecheva; Bao Nguyen; Landon McKinley; John Dee; Emily Wallmueller & Anuj Malla; Daniel Evans; and Mireille Lechliter.

The exhibition opens Friday, May 4 from 5-7pm at the Peale Center, and will remain installed through Sunday, May 6.



April 11-May 6, 2018

[Baker Finalist Showcase](#)

An exhibition of works by [Finalists in the 2018 Baker Artist Awards](#), April 11–May 6. Opening reception: Wednesday, April 11, 6-9pm; [RSVP \(free\)](#)

Featuring [Laura Amussen](#), [Noa Heyne](#), [Christine Neill](#), [David Page](#), [Rachel Rotenberg](#), [Amy Sherald](#), [Susan Waters-Eller](#), [Erick Antonio Benitez](#), [Abraham Burickson](#), [Graham Coreil-Allen](#), [Jeffrey L. Gangwisch](#), [Fred Scharmen](#), and [Stewart Watson](#).

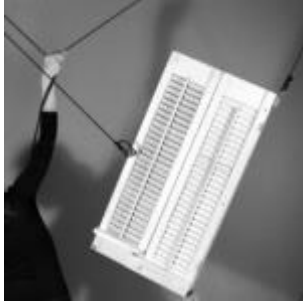

April 14-May 5, 2018

[Moving Walls: A performance of body and sculpture](#)

Noa Heyne, Sidney Pink, Sarah Smith, and Matthew Williams. *Moving Walls* is an experimental dance piece that examines human experience in relation to architecture. Combining movement with sculpture, animation, and sound, the piece is a collaborative project that questions our concepts of stability. With wheels, ropes, pulleys, hooks, and hinges, three performers construct and deconstruct the space around them. In turn, they are influenced by their shifting surroundings. Three Performances. [More information.](#)

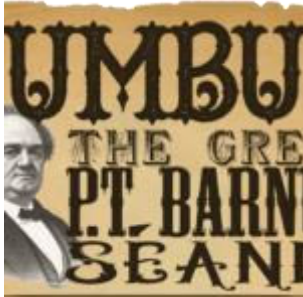

March 8–April 20, 2018

[HUMBUG: The Great P.T. Barnum Seance; Thursdays–Sundays](#)

Hear the incredible true stories of Barnum's life! Encounter genuine artifacts* from Barnum's career! Witness the Fejee Mermaid! Experience Spirit Communication! Bring Barnum and his cast of characters back to life! *Along with reproductions, facsimiles, fakes, frauds and completely fabricated items. [More information.](#)



Friday, April 13, 12-1pm, 2018

[The Man Who Photographed Ghosts: A Talk on Technology, Belief, and Seeing the Dead](#)

A talk by Peter Manseau, Smithsonian Curator of Religion and author of *The Apparitionists*. Peter Manseau is a historian, novelist, and the Lilly Endowment Curator of American Religious History at the Smithsonian Institution's National Museum of American History.

He is the author of eight books and contributes regularly to publications including the Washington Post and the New York Times. His most recent book, *The Apparitionists*, was named one of NPR's Best Books of the Year and Publishers Weekly's Top Ten Books of 2017.

[More information](#) and [RSVP](#) to reserve your place!



Sunday, April 8, 2-4pm, 2018

[Barnum's Museums: Past, Present, and Future](#)

A talk by Kathleen Maher, Executive Director of the Barnum Museum. Kathleen Maher, Executive Director of the [Barnum Museum](#), will talk about Barnum's museums, past, present, and future, and his enduring legacy of growing curiosity, creativity and confidence through instructive entertainment. This talk is being presented in conjunction with [HUMBUG: The Great P.T. Barnum Seance](#), now playing at The Peale Center through April 20, 2018.



Friday, March 16, 12-1pm, 2018

[It's More than History lunchtime lectures](#), presented by the Baltimore National Heritage Area

The [Baltimore National Heritage Area](#) presents the lunchtime lecture series, "It's More than History," at the Peale from February – April 2018. "Off Set: Women Behind the Scenes of Frederick Douglass' Life and Legacy." Brittany Hall is a scholar of African American history and park ranger at the Frederick Douglass National Historic Site. She studies the history of 19th century visual culture, with a special interest in the the preservation of Frederick Douglass' final home as a historic house museum. Ms. Hall's talk will emphasize the important role of women in shaping Frederick Douglass' public image, before and after his death. Women were a crucial part of Frederick Douglass' development as an equal rights activist and preserving his memory for generations to come.

February 16, 11am-12, 2018

[Baltimore National Heritage Area Small Capital Grant Awards](#)

Join Mayor Pugh to congratulate all the grantees of the FY18 BNHA Small Capital Grants Award, then stay for the lunchtime talk, "Off Set: Women Behind the Scenes of Frederick Douglass' Life and Legacy," by Brittany Hall is a scholar of African American history and park ranger at the Frederick Douglass National Historic Site.



February 16, 12-1pm, 2018

[It's More than History lunchtime lectures](#), presented by the Baltimore National Heritage Area

The [Baltimore National Heritage Area](#) presents the lunchtime lecture series, "It's More than History," at the Peale from February – April 2018. All talks are from noon-1pm and are free (lunch not provided). Bring your lunch and join us!

"Learning Happened Here – Race and Education in Baltimore from the Colored School to Frederick Douglass High School." In reconstruction-era Baltimore, the Colored School system was founded to provide public education for African Americans in the City. The historic Peale Museum building, also Baltimore's first City Hall, housed Male and Female Colored School Number One. In 1882, a two-year secondary school program was added to the curriculum, making Colored School Number One the first public high school for African Americans in the state.

The school quickly outgrew the Peale's premises, and was moved first to a larger building on East Saratoga Street, and eventually to a new site at Calhoun and Baker Streets, where it was renamed the Frederick Douglass High School.

Through storytelling and song, this lunchtime presentation traces the historic roots of education for African Americans in Baltimore. [Dr. David Fakunle](#), master storyteller and drummer, will open the program, and will be followed by Dr. Philip J. Merrill: historian, television personality with PBS Chesapeake Collectibles, appraiser, published author, and founder and CEO of Nanny Jack & Co., an African American heritage consulting firm. [More information.](#)



Friday, February 9, 4-6pm, 2018

[Be Here: EDU Workshop #SayItLikeItIS](#)

High school students from the Baltimore area are invited to participate in a series of four workshops about the state of education in Baltimore and beyond. These are opportunities to share your voices and to produce a series of messages that express *your* views about your school and education.

We will hold monthly workshops beginning February 9, 2018. Each workshop's conversation will build upon the previous month's discussions. [More information.](#)



November 16 to December 17, 2017

[H.T. Darling's Incredible Musaeum Presents: The Treasures of New Galapagos, Astonishing Aquisitions from the Perisphere](#)

Submersive Productions returns to the Peale for a limited run of its sold-out immersive theater experience. [Tickets are on sale](#) now and will sell out fast - get yours now!

[More information.](#)



December 6, 7:30-9pm, 2017

[What Can Museums Learn from Immersive Theater?](#)

Inspired by the history and architecture of the Peale, the first purpose-built museum in the US, "H.T. Darling's Incredible Musaeum" immersive theater experience by Submersive Productions offers unique insights into the history and ethics of collecting, curation, and museum practice. Join us for an evening with museum colleagues and the producers and cast members of the show for an in-depth discussion about what museums can learn from immersive theater.

[More information.](#)

With your [ticket](#) to this professional development session are included drinks, appetizers, and \$5 off your purchase of one or more tickets to the H.T. Darling show (subject to availability).



December 10, 10am–1pm, 2017

[H.T. Darling's Incredible Family Day](#)

Families and children are invited to explore an exhibit of objects and creatures from the planet New Galapagos featured in the immersive theater production, *H.T. Darling's Incredible Musæum*. The day includes puppetry, puppet making and theater activities. The December 10th Family Day is free, and open to the public. [More information.](#)



December 12, 7–10pm, 2017

[New Galapagos Gala: A Soiree Among the Specimens](#)

Join Submersive Productions and the cast of H.T. Darling's Incredible Musæum on Tuesday, December 12th from 7 p.m.-10 p.m. for a party at the speed of thought! One night only – [Get your tickets today!](#)



November 1, 6-8pm, 2017

[Do You Dream in Color? Film Screening](#)

The National Federation of the Blind of Maryland, Greater Baltimore Chapter in partnership with the Peale Center for Baltimore History and Architecture hosts a screening of a new, critically acclaimed documentary the problems that blind students experience in public schools and other challenges that they face due to low expectations and misconceptions about blindness. [More information.](#)



October 6-29, 2017

[Birdland and the Anthropocene Exhibition and Programs](#)

At the Peale and through off-site programs, curated by Baker award winner [Lynne Parks](#). The artists in the show offer creative solutions for mitigating human impact on the natural environment of the city, and bird populations in particular: for example by decorating windows and controlling light so that migrating flocks don't run into glass in buildings. [More information.](#)



October 28-29: 11:00 AM - 5:00 PM, 2017

[Doors Open Baltimore](#)

Visit the Peale, its Birdland exhibition, and other

historic buildings around the city – many of which are rarely open – in this year’s extended Doors Open Baltimore weekend. It's a chance to come out and see parts of the city that may have been closed! [More information.](#)



September 28, 2017, 5:00 PM (4pm for tours)

[MW18 Facebook Live Event and Tours of the Peale](#)

Museums and the Web co-chair Nancy Proctor will walk you through the finer details of making a successful proposal to the upcoming [MW18 conference](#) in this event, broadcast at the Peale Center on Facebook Live. Come early for a tour of the first museum ever purpose-built in the United States. The chat is followed by [#drinkingaboutmuseums](#) at Ida B's Table, next door!



September 13, 2017, 7:15 pm

Talk: [The Historic Building as School](#)

Steve Ziger, architect and board member at the Baltimore Design School, will talk about how buildings can support contemporary educational needs and discourses while making visible their historic uses. This talk is part of a series of programs aimed at understanding and contextualizing the Peale's own past as Colored School No. 1 (1878-1889) and its role in the history of Baltimore schools and the city's educational system.



September 9, 2017, 10:00 AM - 4:30 PM

[Collecting Baltimore School Stories - a Be Here.Edu Workshop](#)

We're recruiting community members who would like to contribute to an upcoming exhibition and programming that will feature stories of Baltimore's public schools and trace the roots of contemporary issues to segregation and the city's Colored School system, including the Peale's own past as "[Colored School Number One](#)." Part of the [Be Here. Edu](#) program, this design and planning meeting led by the [Omnimuseum Project](#) and the [MuseWeb Foundation](#).



September 7, 2017, 2-3:30 PM

[Tour the Peale](#)

Get a tour of the Peale, the first purpose-built museum in the country, and hear about how it is being reimagined as a production house of culture. Discuss educational programming for the Peale's target audiences, families and schools, and help develop ideas for the Peale's Be Here: EDU cultural storytelling initiative.



August 24, 2017, 5:30 PM - 8:00 PM

[Tour of Downtown Baltimore Historic Skyscrapers](#)

Join the Baltimore Architecture Foundation, the Downtown Partnership of Baltimore, and the Peale Center for a tour of Downtown Baltimore historic skyscrapers. [More information.](#)



Founder's Day Open House 14-15 August 2017

Full program

August 15

11 am - 5 pm: Tours & Storytelling

11 am - 5 pm: Be Here: Baltimore

11 am - 5 pm: Visualizing Early Baltimore

12:30pm: 100 Gems of Light: The Peale Family and the 1816 Birth of the Baltimore/American Gas Industry

Talk by Burt Kummerow, principal of Historyworks and former President of the Maryland Historical Society.

August 14, 2017

11 am - 1 pm: Puppet Theater

After an apprenticeship with a puppetmaster in Chicago, Schroeder Cherry set out on his my own and began producing stories using puppets. A native of Washington, DC, Schroeder and his puppet, DiAndre, present the story of Baltimore's Street Lights--another "invention" of Rembrandt Peale-- in this special command performance, adapted from Cherry's 2016 Light City act.

August 14, 2017

11 am - 5 pm: Tours & Storytelling

Drop in anytime to explore the historic Peale building and hear stories of its many firsts. Tours are led on a rotating basis by Peale experts and storytellers including curator Dean Krimmel, historian Alicia Puglionesi, Peale Board President Jim Dilts, and Peale Director Nancy Proctor. [Let us know you are coming](#), and we'll send you updates on additional tour leaders and their schedules.

August 14, 2017

11 am - 5 pm: Be Here: Baltimore

Throughout the Open House you can listen to and add your own Baltimore stories to the 1200+ already part of the [Be Here: Baltimore](#) project at its new home in the Peale Center. This is an opportunity for neighbors and residents to show people around the world what Baltimore is REALLY like.

August 14, 2017

11 am - 5 pm: Visualizing Early Baltimore

This eye-popping 3D interactive digital reconstruction of Baltimore circa 1815 took UMBC's Imaging Research Center (IRC) more than 4 years to develop. In September of 2014, the first and major phase of this effort, called [BEARINGS of Baltimore, Circa 1815](#), opened to the public at the Maryland Historical Society as part of their bicentennial celebration of Baltimore's pivotal role in the War of 1812. In 2016 the IRC did a major upgrade of the image to increase its accuracy, amount of information, and level of detail. This new image will be on display at the Peale throughout the Founder's Day Open House. Explore the Peale's neighborhood and the rest of the city as it looked after the British attacks in 1814.

August 14, 2017

6pm - 8pm: Live Storytelling with Aaron Henkin

A cross-section of locals from around the 200 block of Holliday Street join Aaron Henkin, producer of WYPR's "Out of the Blocks" series, for a neighborhood storytelling event in front of a live audience at the Peale. Seating is free but limited so [RSVP to reserve your place!](#)



July 8, 2017

Social Science Encounters

Design Charette led by the Omnimuseum Project. The goal of Social Science Encounters is to engage people in everyday public settings in ways that deepen their sense of empathy and recognition of a common ground with others around them. [More information.](#)



March 30–May 14, 2017

H.T. Darling's Incredible Musaeum Presents

The Treasures of New Galapagos, Astonishing Aquisitions from the Perisphere" immersive theater from Submersive Productions. [More information.](#)